

## Builders Notes and Technical Drawings

- Building the valve and fast ionization gauge (FIG) require technical and machining prowess. While all the parts can (and were) machined in a home shop and do not require any special tooling, there are tight tolerances, small stainless steel parts, fine threads, and micro holes drilled through ceramic.
- The objective of this section is to provide a few “tips and tricks” to making and assembling the parts for the pulsed valve and FIG, and performing the initial setup of the valve. This is not an intended to be an instruction manual, but rather a place to share some insights we gained during this process, and the procedure we followed.
- Here we also present the complete plans and assembly drawings for building the valve and FIG, as well as the electrical circuit diagrams.

### Pulsed Valve

#### Valve Body

- The body was intentionally made from easy to machine 303 stainless steel, and requires no special techniques to machine.
- The bore is 0.002” (0.051 mm) oversized to allow for the piston to slip fit nicely into it.

#### Piston

- Brass was chosen for the piston material because it was easier to cut the relief in the back for the spring. As discussed in the paper, the piston could be made from stainless steel.
- The piston is fitted with two Viton o-rings (1.5” OD x 1/16” CS) which serve to dampen any play between the piston the body of the valve.
- The ¼ x 80 tap needed to cut the thread into the back of the piston is available from McMaster-Carr.

#### Micrometer feed through

- The feed through is also made from easy to machine stainless steel
- The ¼ x 80 die needed to cut the thread is also available from McMaster-Carr. We cut the thread before machining the o-ring grooves.
- On our valve the micrometer has a knurled surface, which we found isn’t really needed, since the spring pressure is enough to always want to use a wrench to turn the micrometer.
- We lubricated the threads of the micrometer, and the o-rings, with silicon vacuum grease.

#### Nozzle and Faceplate

- A MACOR insert was chosen for the nozzle because we needed it to be electrically insulating. But it works out to the builder’s advantage because drilling 250  $\mu\text{m}$  holes in MACOR is easier than stainless steel, brass, or aluminum.
- Drill bits in this size range sound exotic, but they’re readily available (we got ours from Amazon).

- Also, a micro center drill is key to starting the hole.
- When machining MACOR we used water as a lubricant and cooling agent, except for when drilling the 250  $\mu\text{m}$  hole. We drilled this hole dry so that the ceramic dust doesn't create a paste which clogs the flutes of the drill bit.
- We found that the trick to drilling this hole is to only plunge 0.002" (0.051 mm) at a time, back the drill bit all the way out and clean it with compressed air. Drill the micro hole first and about 0.010" (0.254 mm) deeper than the plans call for. Then you can meet it from the other side with the 40° "V" cutter.
- The 40° "V" cutter we used is an engraving tool with a 0.003" (0.076 mm) tip radius

#### Micro o-ring

- The o-ring we used was made by Precision Associates and has part number 10-10 9746.
- When we first built the nozzle, how to glue an o-ring the size of a poppy seed directly over a hole which is equally small was not immediately evident. We threaded the o-ring onto a 30 gauge wire and then threaded the wire through the nozzle orifice. Suspending the o-ring above the nozzle, we spread epoxy carefully on the nozzle face around the orifice. Then we pulled the wire through and the o-ring seated itself in the epoxy directly over the hole.
- The high temperature epoxy we used is available from Thorlabs and has part number 353NDPK. Let it set for 24 hours before curing it in an oven at 80 °C for 20 minutes, otherwise its excellent wicking capability when heated will cause it to spread all over the parts.
- This epoxy was also used to bond the ceramic nozzle insert to the faceplate.

#### Piezo

- The PZT was purchased from STEMINC Piezo and has part number SMBA4510T05M
- They come 40 mm in length and we cut them down using a sheet metal shear
- The PZT is factory wired for series operation, but we chose to remove the jumper between the ceramic halves and use it in a parallel poled (3 wire) configuration. In this mode the electric field is always in the direction of polarization which eliminates the risk of depolarizing the PZT due to strong electric field gradients.
- In this configuration, one electrode is grounded, the other is held at the maximum positive voltage, and the driving signal is sent to the center brass strip.
- We used the body of the valve as ground, and a 30 gauge teflon coated wire soldered directly to the center brass strip to provide the driving signal (purple in the picture of the valve), and another teflon coated wire to provide the static voltage (white). This wire was soldered to a separate piece of brass shim stock and sandwiched between the piezo and the bridge clamp. A thin sheet of mica was used to insulate the electrode from the bridge clamp.
- All the layers were electrically isolated from one another using Kapton tape.
- The wires were left long and coiled inside the body of the valve during assembly.
- The Kapton gasket which seals against the o-ring was made from Kapton tape which is 0.005" (0.127 mm) thick and can be bought on a spool which is 0.125" (3.18 mm) wide.

#### Valve Assembly and Initial Set Up

- We started the assembly by soldering the teflon insulated wires onto the Lemo electrical connectors (part number EWV.00.250.NTLPV), and then screwing the Lemo connectors into the adapters, and then screwing that assembly plus the gas fitting into the back of the valve body. We greased each o-ring with silicon vacuum grease.
- We fed the wires through the spring and through one of the holes in the piston, and soldered the wires to the PZT and the other brass electrode.
- Then we inserted the micrometer through the back of the valve and thread it into the piston, retracting the piston all the way into the valve.
- We fed the excess wire into the body of the valve
- We installed the PZT under the bridge clamp leaving about 0.210" of cantilevered free length, we did this using a caliper, and positioned the PZT in the center of the piston by eye. It's tricky here to get the brass shim (high voltage electrode) and the mica insulator positioned properly under the bridge clamp, it took us a few tries.
- Make sure the piston is retracted all the way and then install the faceplate (with a greased o-ring). The bridge clamp needs to line up with the relief cut into the faceplate. If this is not the case, then rotate the piston by spanning the two holes with a pair of needle nose pliers.
- Once the faceplate screws were tightened down we pressurized the valve. It leaked immediately, which was expected.
- While running the valve at 1 kHz we turned the micrometer counter clock wise to close the valve until the continuous flow became a pulse. Then we turned the valve off and checked for leaks by holding the valve upright and squirting alcohol into the nozzle. If we saw bubbles, we closed the valve more. Once the valve didn't leak it was installed in the vacuum chamber and fine tuning of the valve operation was be done using the fast ionization gauge

#### Fast Ionization Gauge

- In our opinion, the FIG was as important to developing a pulsed gas source as the valve itself. Having a real-time measurement of the duration and intensity of the gas pulse has proven invaluable in our lab when performing the initial setup of the pulsed valve and after changing any of the operating parameters (backing gas pressure, type, temperature of the valve, etc...). It was such a critical diagnostic tool that we keep the FIG on a linear translator which can move the detector into and out of the pulsed beam.
- The FIG depicted in the following plans is one of our designs which is meant to be mounted on a post inside a vacuum chamber. We also built a FIG which was designed to be a coupling between lengths of KF40 pipe and does not require such an elaborate infrastructure (i.e. vacuum chamber with gas, electric, and mechanical feedthroughs) to develop and test this valve. The plans presented here can easily be adapted to this inline design.

#### FIG Building Notes

- The complex part of building the FIG was making and aligning the collector, grid, and filament.

- We wound the grid and filament ourselves from tungsten wire, around a mandrel, on an engine lathe to a pitch of 28 turns per inch. And, the collector was made from 0.010" (0.254 mm) TIG welding electrode.
- The alignment of the collector down the center of the grid is critical. In order to do this, we first assembled the detector head of the FIG installing the grid, but leaving out the collector itself (also leaving off the filament). Then, we threaded the ferrule onto the collector and then inserted the collector into the collector support bushing. We propped up the entire assembly such that the collector was aligned down the center of the grid, and then epoxied the collector in place.
- The other challenging step to making the FIG was assembling the filament. We wound the filament leaving plenty of extra material on each end, which was looped under the screws to make the electrical connection. We also constructed 3 filament supports from 0.010" (0.254 mm) tungsten wire which we discovered were necessary to keep the filament in shape when it got hot. Two of them were also looped under the screws and the central support was tied around the MACOR filament bushing (being careful not to accidentally ground it). Assembling everything while keeping the filament to grid distance about 0.1" (2.54 mm) required patience and a steady hand.
- The amplifier for the FIG was mounted in the base of the detector, which was as close to the collector as possible. This was done to keep the capacitance as low as possible as well as reduce losses since the current from the collector is on the order of tens of nA.

#### FIG Electronics

- The amplifier circuit was easy to build; however the op amp is prone to oscillating in this configuration. We found that we could alleviate these oscillations by separating the components as far away from each other as possible on the circuit board.

#### Pulsed Valve Electronics and Microprocessor

- The amplifier for the pulsed valve was also easy to construct.
- The control signal doesn't have to come from a homemade box—we just happened to have a microprocessor (made by microchip about 15 years ago) mounted to a board already wired with GPIO pins and serial data in and out. All that matters is that the amplifier is given a 3.3 V digital pulse, with variable pulse duration, repetition rate, and delay so that the valve can be in time with a laser. The first prototype of this controller was made using a Teensy, which is an "Arduino like" development board. But, we were unable to get under 2  $\mu$ s of jitter in the timing from Teensy.
- If we were to make the controller again, we would probably use Atmel Studio and a compatible development board.

#### Characterization of the Driving Signal

- The driving signal is a square wave, 20  $\mu$ s in duration, with about 5  $\mu$ s ramps at either end due to the slew rate of the op amp.
- Pictured below is a 100 V driving signal together with the FIG response to the pulse of helium.

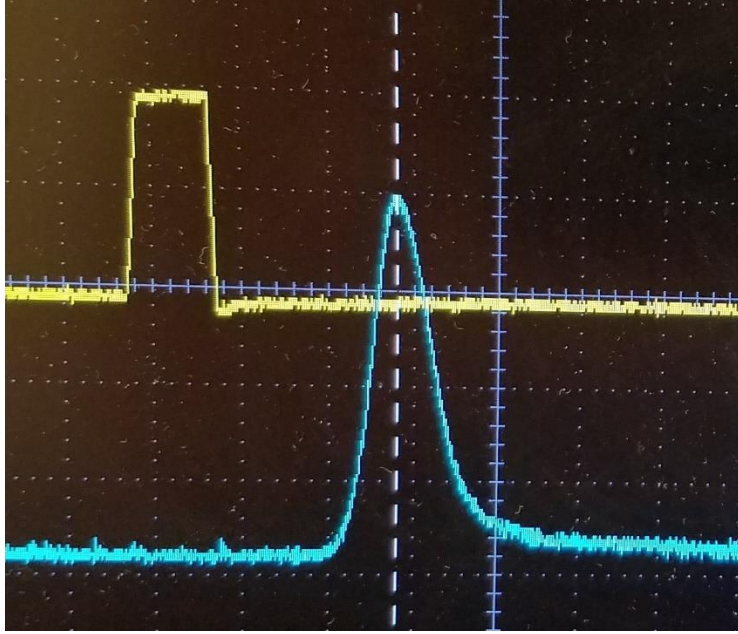

Scope screen picture showing both driving signal (yellow) and FIG output (blue). The time division is 20  $\mu\text{s}$  per major box.

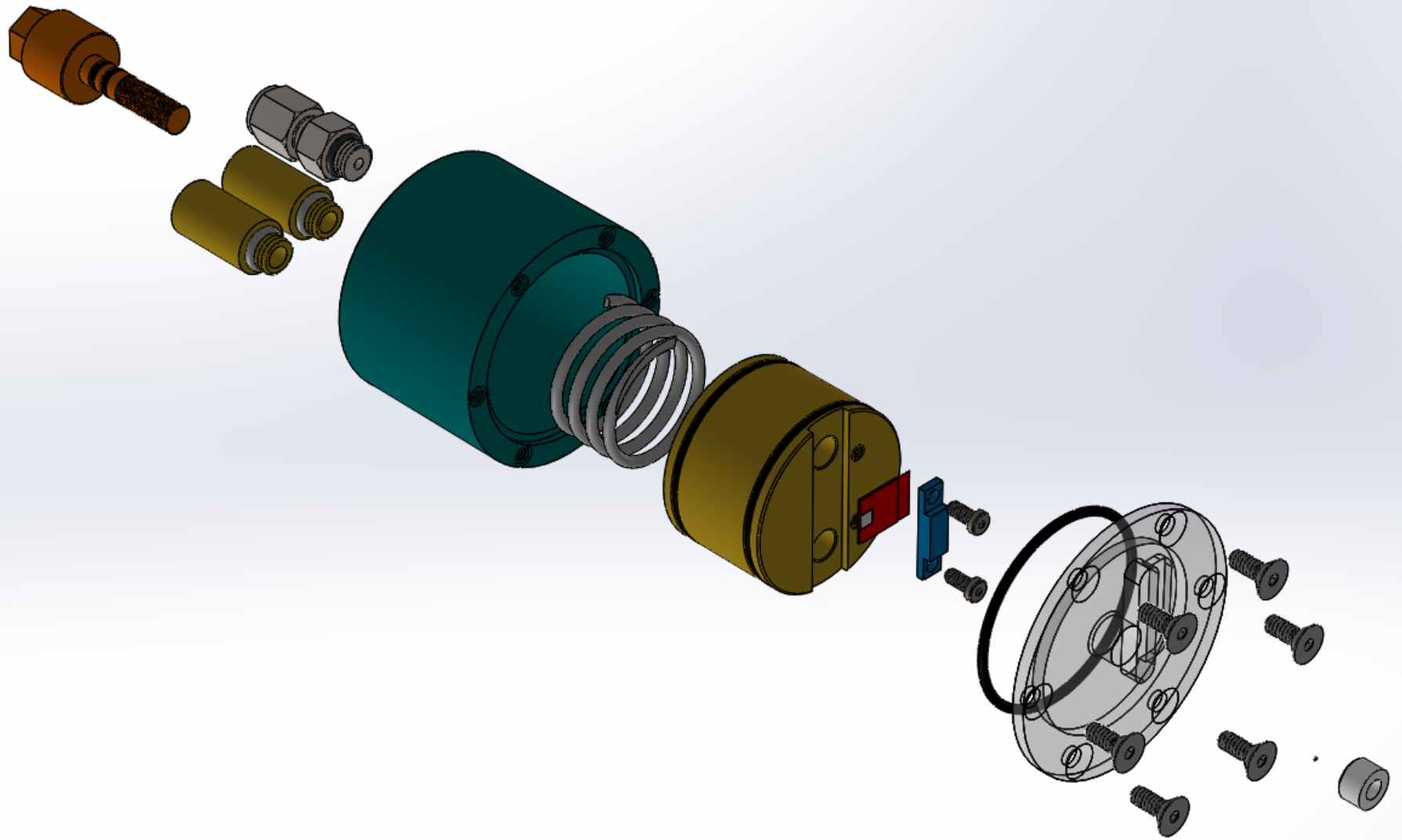

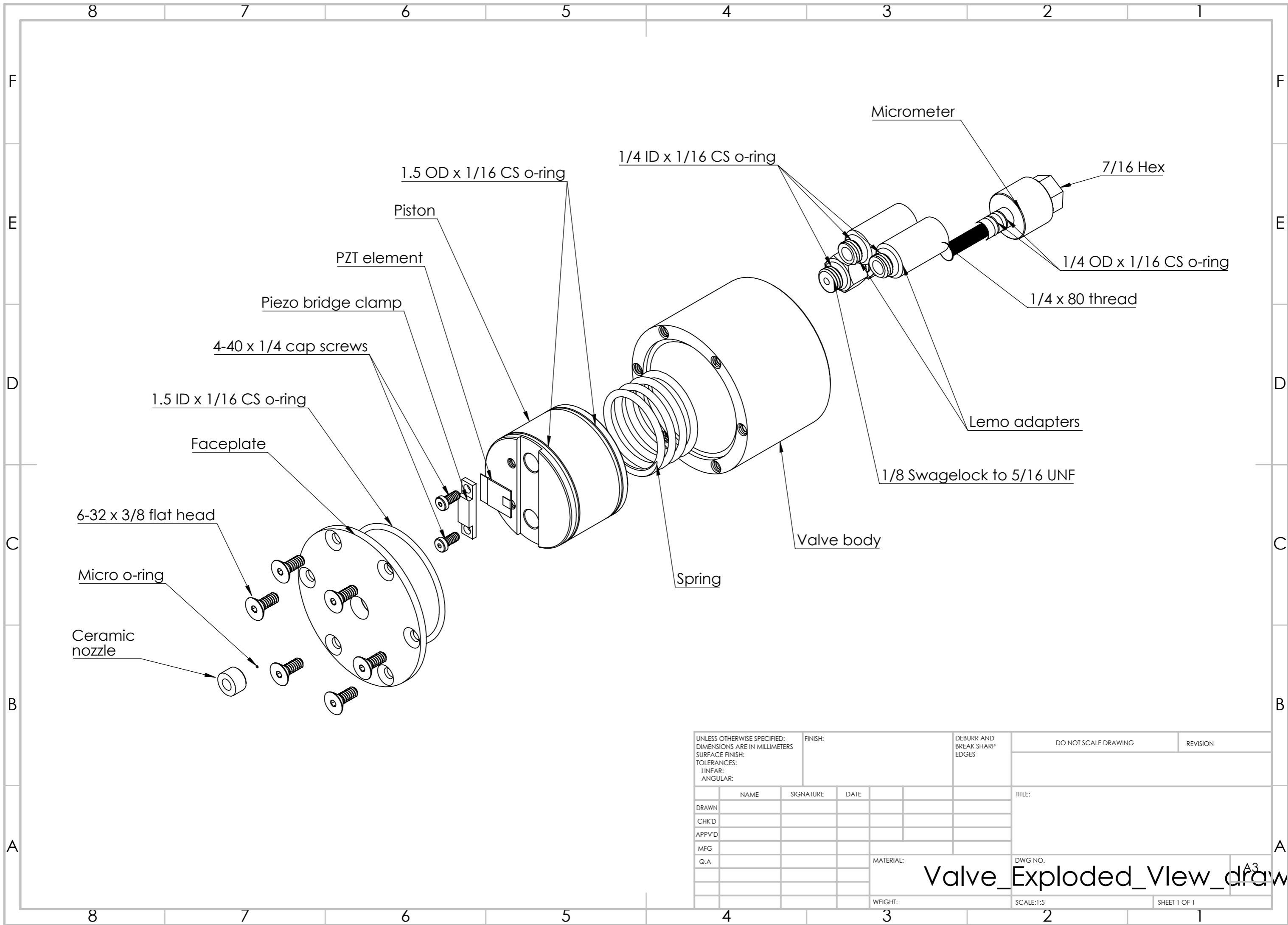

UNLESS OTHERWISE SPECIFIED: DIMENSIONS ARE IN MILLIMETERS SURFACE FINISH: TOLERANCES: LINEAR: ANGULAR:				FINISH:		DEBURR AND BREAK SHARP EDGES		DO NOT SCALE DRAWING		REVISION	
DRAWN				NAME		SIGNATURE		DATE		TITLE:	
CHK'D											
APPV'D											
MFG											
Q.A								MATERIAL:		DWG NO.	
								WEIGHT:		SCALE:1:5	
										SHEET 1 OF 1	

Valve\_Exploded\_View\_drawing

A3

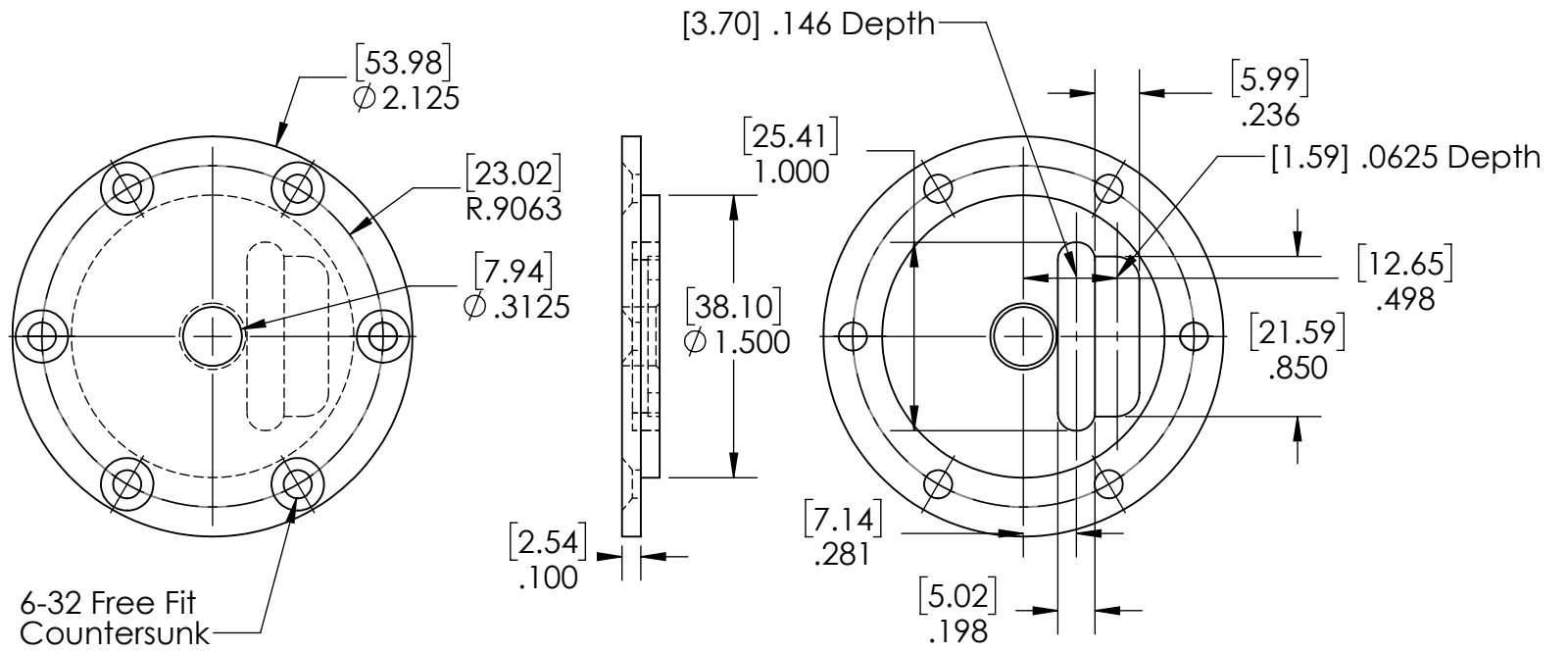

UNLESS OTHERWISE SPECIFIED: DIMENSIONS ARE IN MILLIMETERS SURFACE FINISH: TOLERANCES: LINEAR: +/- 0.002 ANGULAR: +/- 1 deg			FINISH:		DEBURR AND BREAK SHARP EDGES		DO NOT SCALE DRAWING		REVISION	
DRAWN			SIGNATURE		DATE		TITLE:			
CHK'D										
APPV'D										
MFG										
Q.A					MATERIAL: Stainless Steel		DWG NO.		A4	
							FrontCover			
					WEIGHT:		SCALE:1:1		SHEET 1 OF 1	



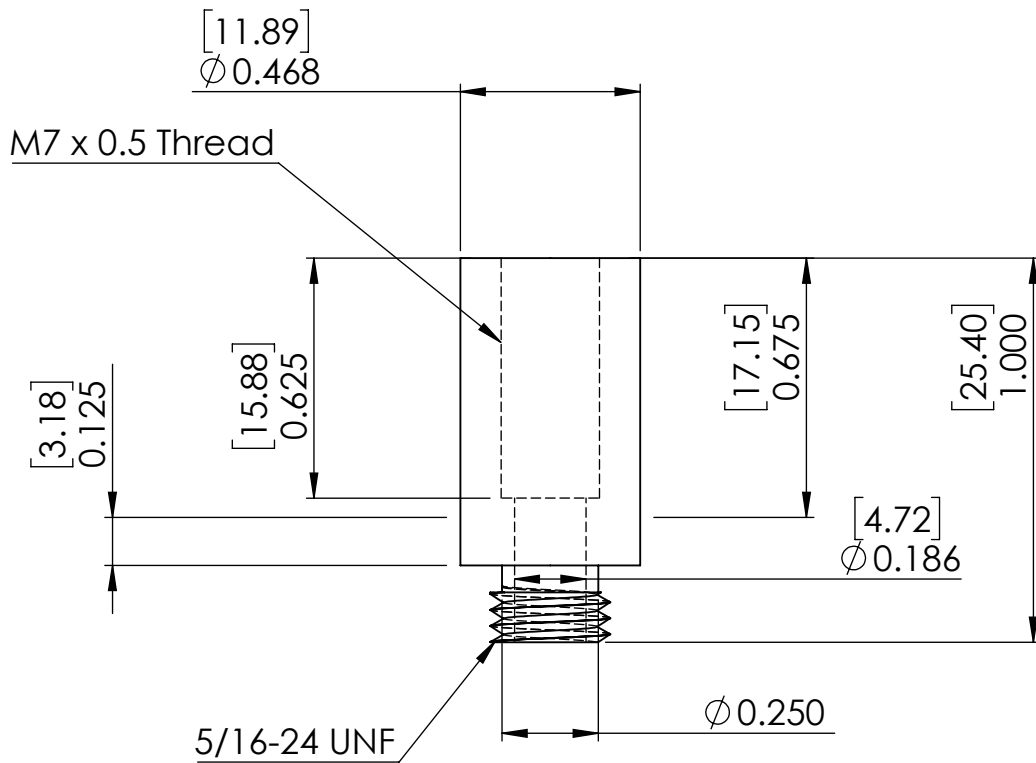

UNLESS OTHERWISE SPECIFIED:  
 DIMENSIONS ARE IN MILLIMETERS  
 SURFACE FINISH:  
 TOLERANCES:  
 LINEAR: +/- 0.002  
 ANGULAR: +/- 1 deg

FINISH:

DEBURR AND  
 BREAK SHARP  
 EDGES

DO NOT SCALE DRAWING

REVISION

	NAME	SIGNATURE	DATE
DRAWN			
CHK'D			
APPV'D			
MFG			
Q.A			

TITLE:	
MATERIAL: Stainless Steel	DWG NO.
	<b>LemoAdapter</b>
WEIGHT:	SCALE:2:1
	SHEET 1 OF 1

A4

6

5

4

3

2

1

D

D

C

C

B

B

A

A

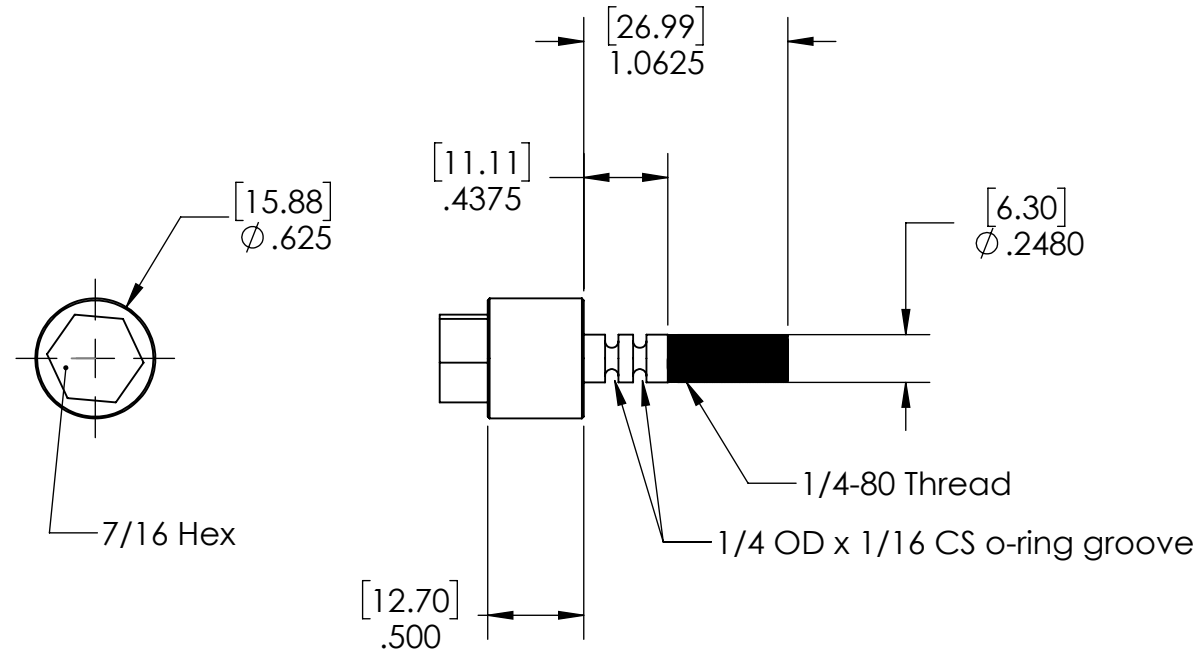

UNLESS OTHERWISE SPECIFIED: DIMENSIONS ARE IN MILLIMETERS SURFACE FINISH: TOLERANCES: LINEAR: +/- 0.002 ANGULAR: +/- 1 deg			FINISH:		DEBURR AND BREAK SHARP EDGES		DO NOT SCALE DRAWING		REVISION	
DRAWN			SIGNATURE		DATE		TITLE:			
CHK'D										
APPV'D										
MFG										
Q.A					MATERIAL: Stainless Steel		DWG NO.		A4	
							Micrometer			
					WEIGHT:		SCALE: 1:1		SHEET 1 OF 1	

6

5

4

3

2

1

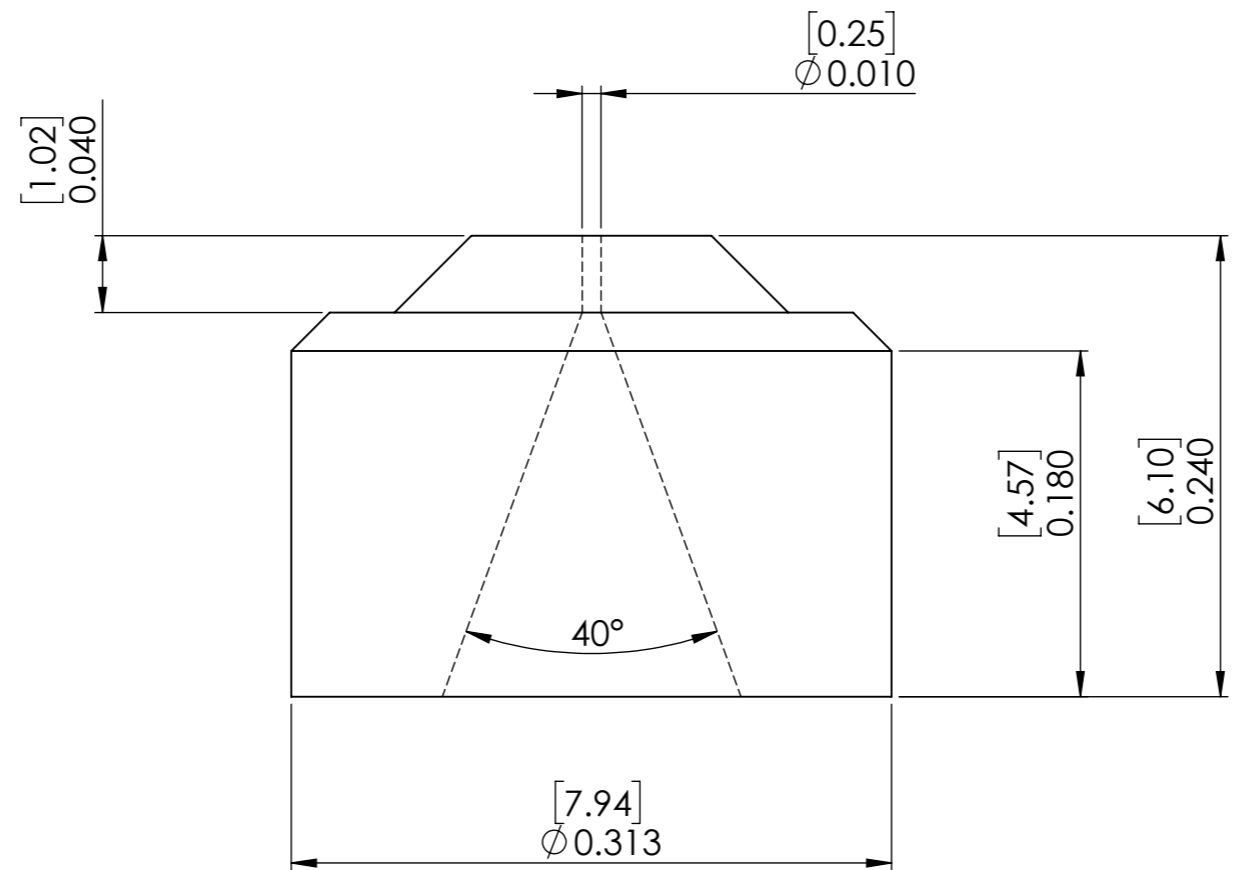

UNLESS OTHERWISE SPECIFIED: DIMENSIONS ARE IN MILLIMETERS SURFACE FINISH: TOLERANCES: LINEAR: +/- 0.002 ANGULAR: +/- 1 deg				FINISH:		DEBURR AND BREAK SHARP EDGES		DO NOT SCALE DRAWING		REVISION	
DRAWN				NAME		SIGNATURE		DATE		TITLE:	
CHK'D											
APPV'D											
MFG											
Q.A								MATERIAL: MACOR		DWG NO.	
										Nozzle	
										A3	
								WEIGHT:		SCALE:10:1	
										SHEET 1 OF 1	

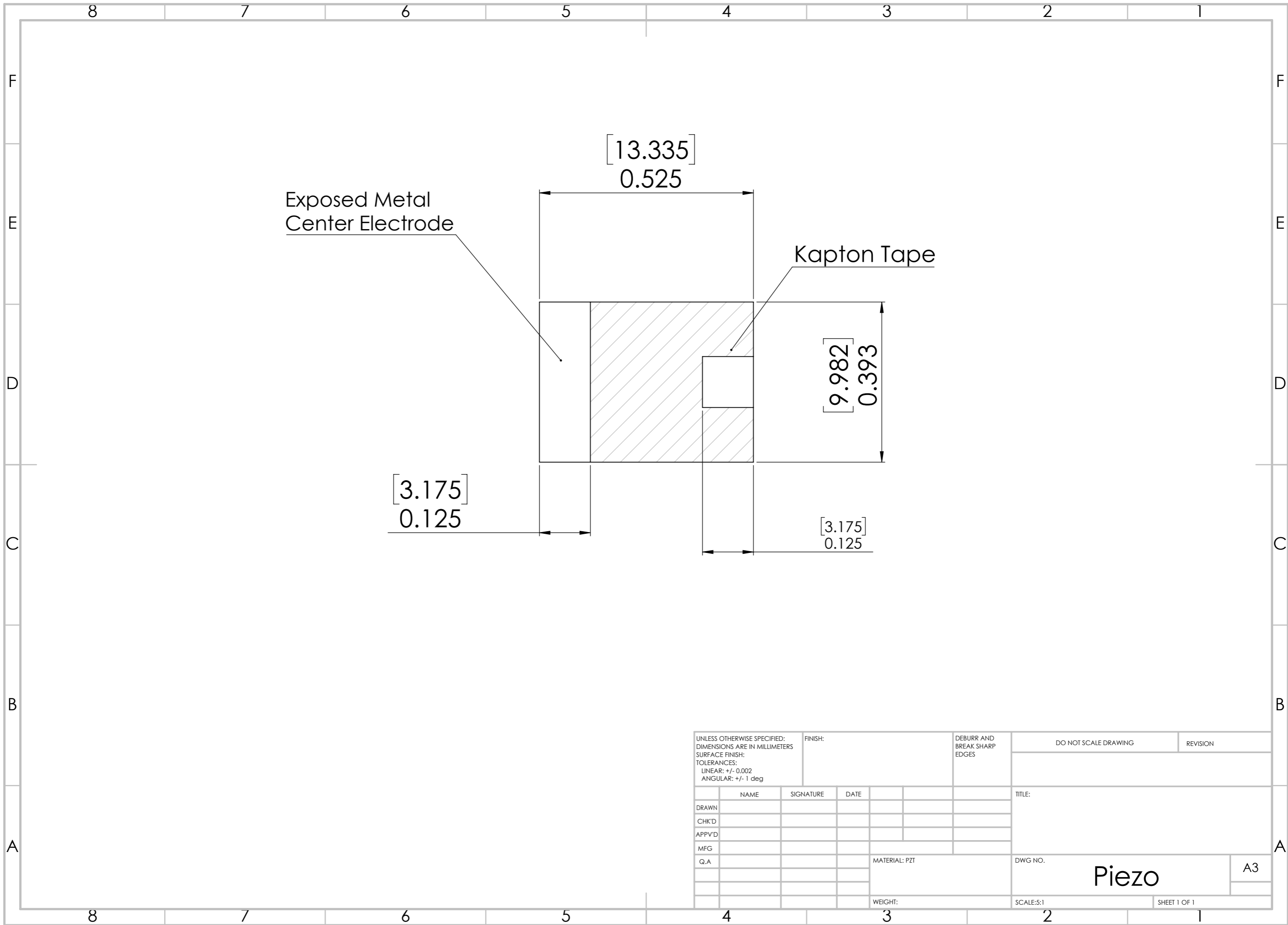

UNLESS OTHERWISE SPECIFIED: DIMENSIONS ARE IN MILLIMETERS SURFACE FINISH: TOLERANCES: LINEAR: +/- 0.002 ANGULAR: +/- 1 deg			FINISH:		DEBURR AND BREAK SHARP EDGES		DO NOT SCALE DRAWING		REVISION		
DRAWN			NAME		SIGNATURE		DATE		TITLE:		
CHK'D											
APPV'D											
MFG											
Q.A							MATERIAL: PZT		DWG NO.		A3
							WEIGHT:		SCALE:5:1		SHEET 1 OF 1

Piezo

6

5

4

3

2

1

D

D

C

C

B

B

A

A

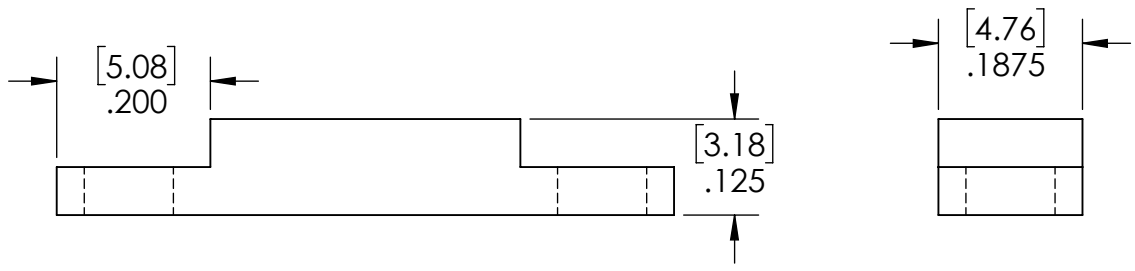
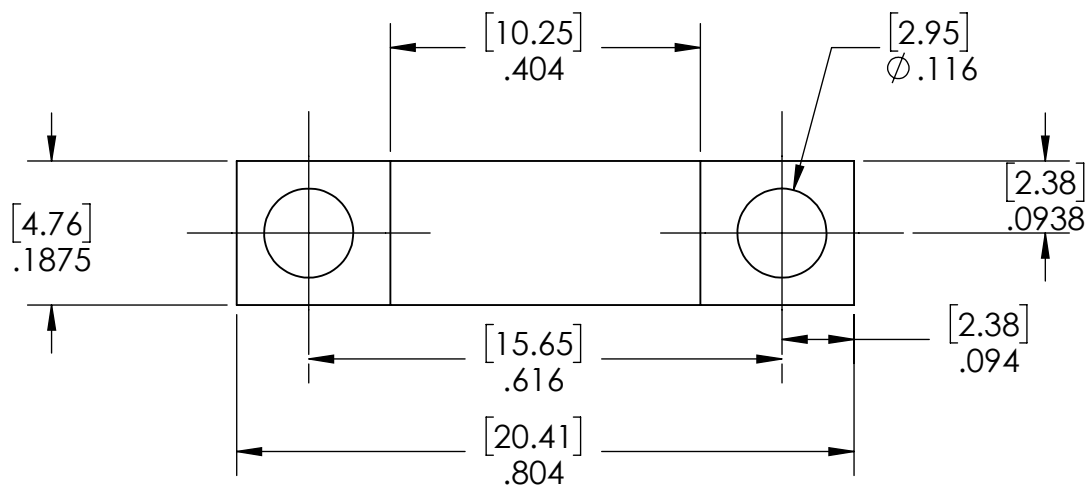

UNLESS OTHERWISE SPECIFIED: DIMENSIONS ARE IN MILLIMETERS SURFACE FINISH: TOLERANCES: LINEAR: +/- 0.002 ANGULAR: +/- 1 deg			FINISH:		DEBURR AND BREAK SHARP EDGES		DO NOT SCALE DRAWING		REVISION		
DRAWN			SIGNATURE		DATE		TITLE:				
CHK'D											
APPV'D											
MFG											
Q.A							MATERIAL: Stainless Steel		DWG NO.		A4
							WEIGHT:		SCALE:4:1		SHEET 1 OF 1

# PiezoClamp

6

5

4

3

2

1

6 5 4 3 2 1

D  
C  
B  
A

D  
C  
B  
A

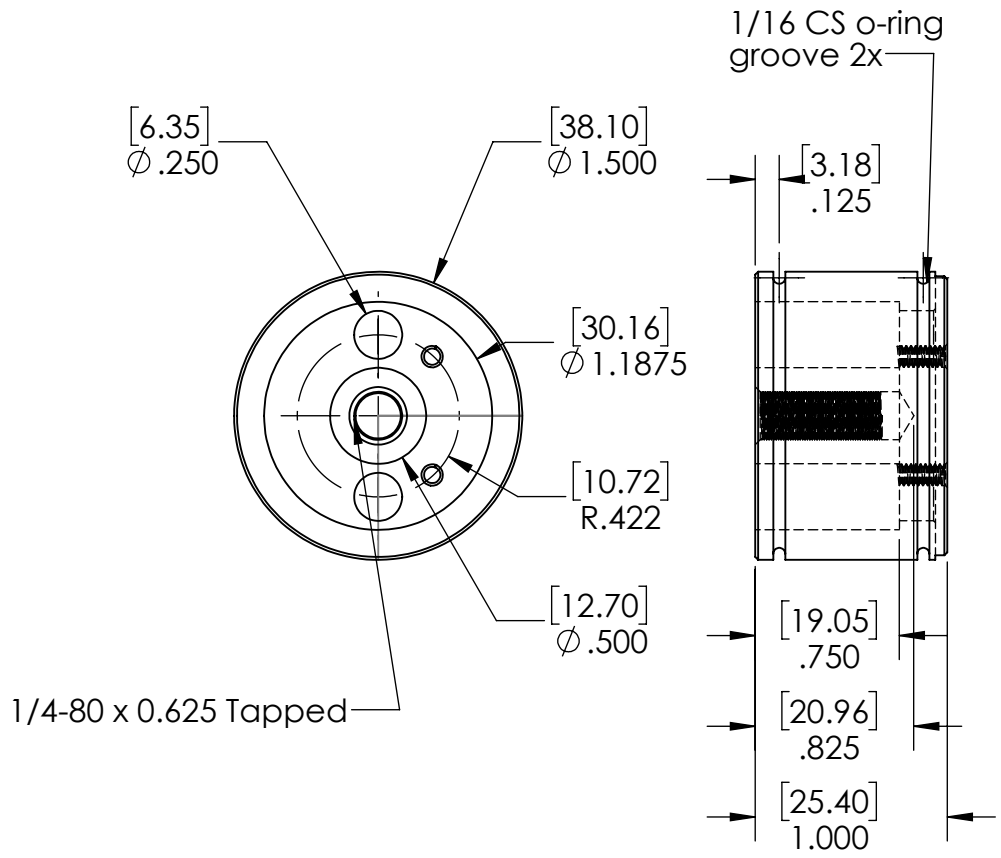

UNLESS OTHERWISE SPECIFIED: DIMENSIONS ARE IN MILLIMETERS SURFACE FINISH: TOLERANCES: LINEAR: +/- 0.002 ANGULAR: +/- 1 deg				FINISH:		DEBURR AND BREAK SHARP EDGES		DO NOT SCALE DRAWING		REVISION	
DRAWN				SIGNATURE		DATE		TITLE:			
CHK'D											
APPV'D											
MFG											
Q.A						MATERIAL: Brass		DWG NO.		A4	
								PistonBack			
						WEIGHT:		SCALE:1:1		SHEET 1 OF 1	

6 5 4 3 2 1

6

5

4

3

2

1

D

D

C

C

B

B

A

A

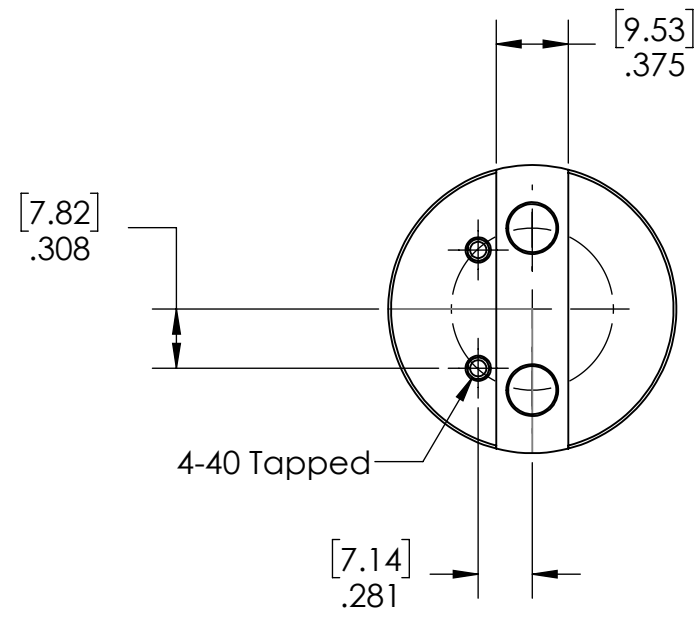

UNLESS OTHERWISE SPECIFIED: DIMENSIONS ARE IN MILLIMETERS SURFACE FINISH: TOLERANCES: LINEAR: +/- 0.002 ANGULAR: +/- 1 deg			FINISH:		DEBURR AND BREAK SHARP EDGES		DO NOT SCALE DRAWING		REVISION	
DRAWN			SIGNATURE		DATE		TITLE:			
CHK'D										
APPV'D										
MFG										
Q.A					MATERIAL: Brass		DWG NO.		A4	
					WEIGHT:		SCALE:1:1		SHEET 1 OF 1	

PistonFront

6

5

4

3

2

1

6

5

4

3

2

1

D

D

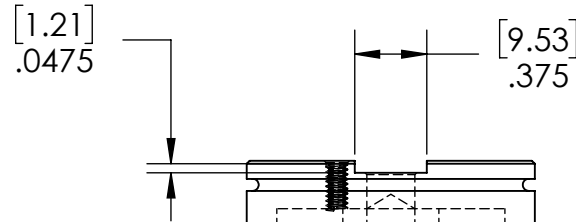

1/4-80 Thread

C

C

B

B

A

A

UNLESS OTHERWISE SPECIFIED: DIMENSIONS ARE IN MILLIMETERS SURFACE FINISH: TOLERANCES: LINEAR: +/- 0.002 ANGULAR: +/- 1 deg			FINISH:		DEBURR AND BREAK SHARP EDGES		DO NOT SCALE DRAWING		REVISION		
DRAWN			SIGNATURE		DATE		TITLE:				
CHK'D											
APPV'D											
MFG											
Q.A					MATERIAL: Brass		DWG NO.		A4		
							PistonSide				
					WEIGHT:		SCALE:1:1		SHEET 1 OF 1		

6

5

4

3

2

1



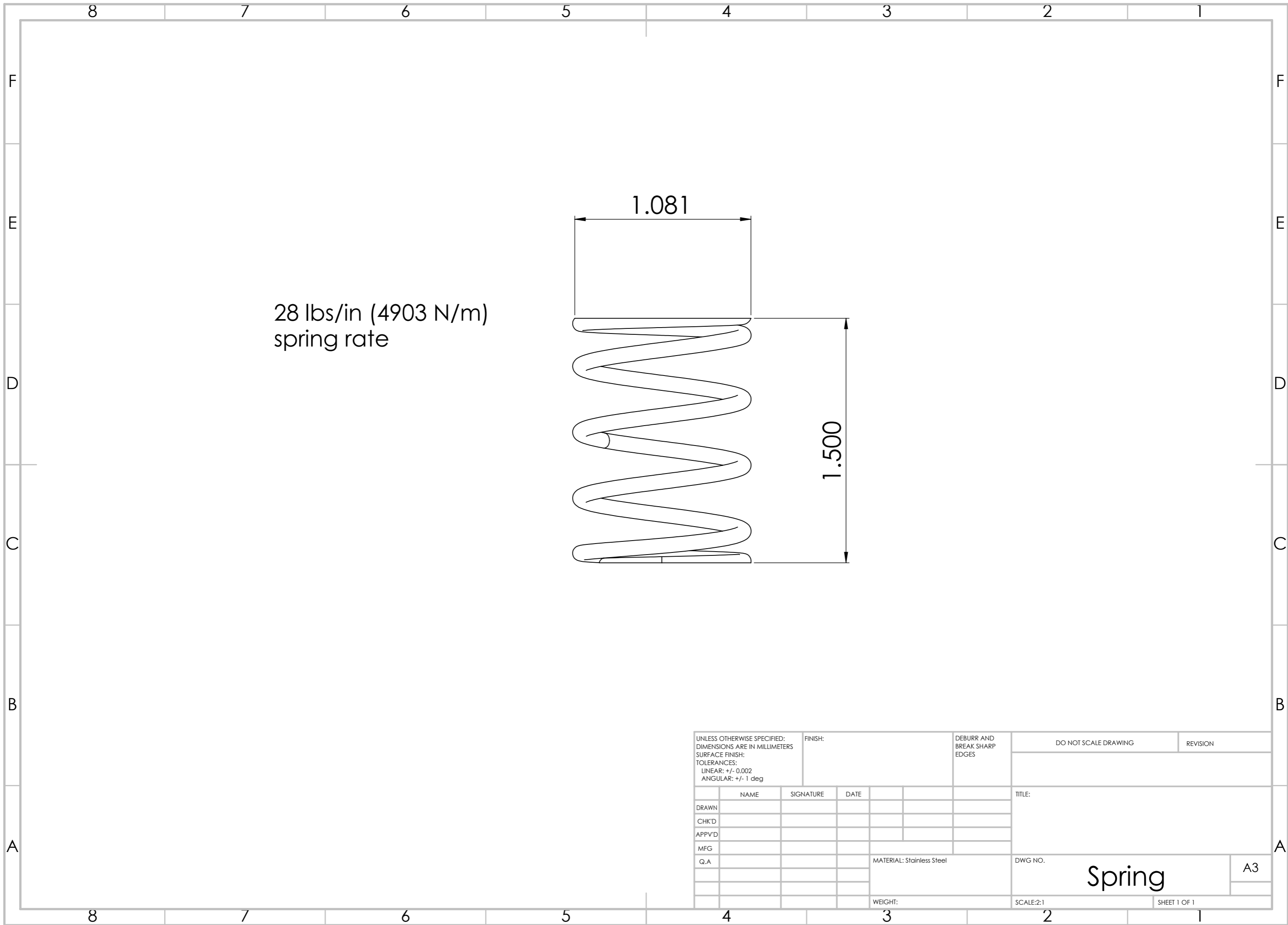

UNLESS OTHERWISE SPECIFIED: DIMENSIONS ARE IN MILLIMETERS SURFACE FINISH: TOLERANCES: LINEAR: +/- 0.002 ANGULAR: +/- 1 deg				FINISH:		DEBURR AND BREAK SHARP EDGES		DO NOT SCALE DRAWING		REVISION	
								TITLE:			
DRAWN				NAME		SIGNATURE		DATE			
CHK'D											
APPV'D											
MFG											
Q.A								MATERIAL: Stainless Steel		DWG NO.	
										Spring	
								WEIGHT:		SCALE:2:1	
										SHEET 1 OF 1	
										A3	

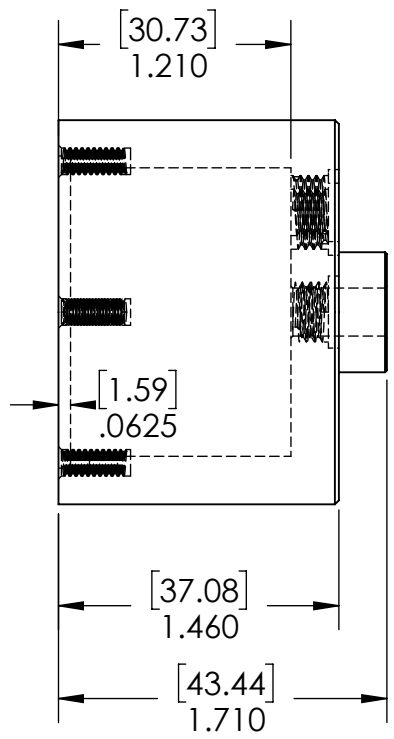
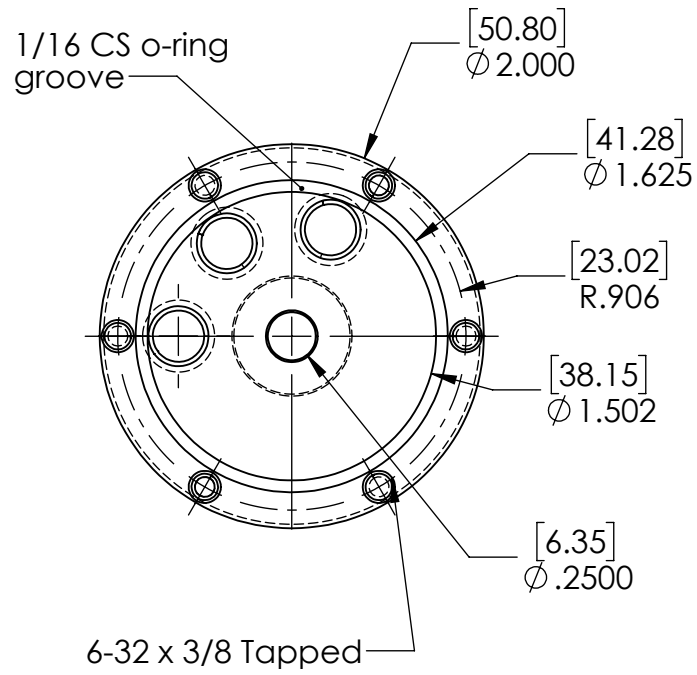

UNLESS OTHERWISE SPECIFIED: DIMENSIONS ARE IN MILLIMETERS SURFACE FINISH: TOLERANCES: LINEAR: +/- 0.002 ANGULAR: +/- 1 deg				FINISH:		DEBURR AND BREAK SHARP EDGES		DO NOT SCALE DRAWING		REVISION	
								TITLE:			
DRAWN		SIGNATURE		DATE							
CHK'D											
APPV'D											
MFG											
Q.A				MATERIAL: Stainless Steel				DWG NO.		A4	
				WEIGHT:				SCALE: 1:1		SHEET 1 OF 1	

ValveBody.

6

5

4

3

2

1

D

D

C

C

B

B

A

A

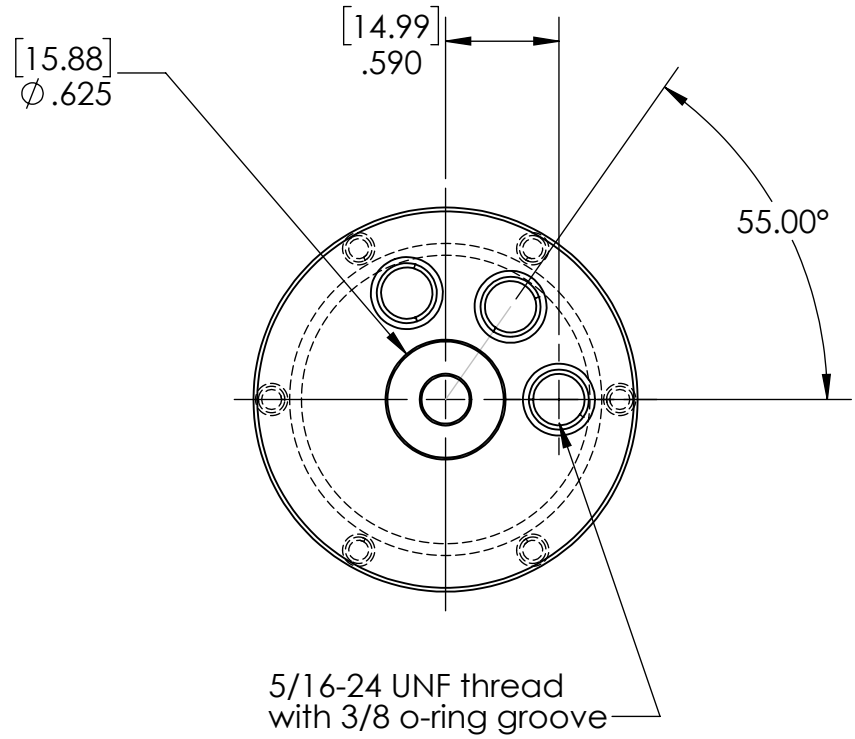

UNLESS OTHERWISE SPECIFIED: DIMENSIONS ARE IN MILLIMETERS SURFACE FINISH: TOLERANCES: LINEAR: +/- 0.002 ANGULAR: +/- 1 deg			FINISH:		DEBURR AND BREAK SHARP EDGES		DO NOT SCALE DRAWING		REVISION	
DRAWN			SIGNATURE		DATE		TITLE:			
CHK'D										
APPV'D										
MFG										
Q.A					MATERIAL: Stainless Steel		DWG NO.		A4	
							ValveBodyBack			
					WEIGHT:		SCALE:1:1		SHEET 1 OF 1	

6

5

4

3

2

1

# PZT Amplifier

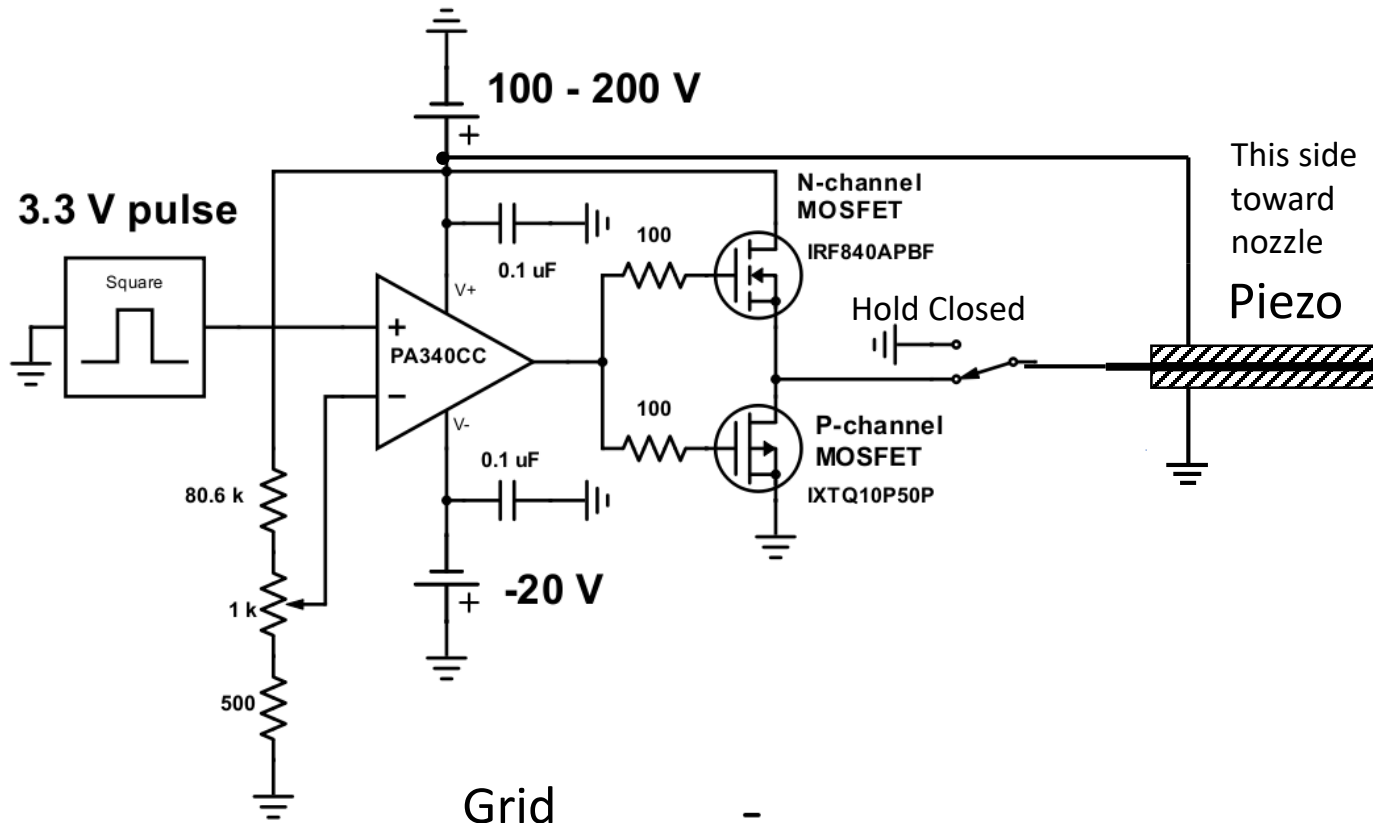

# FIG Electronics

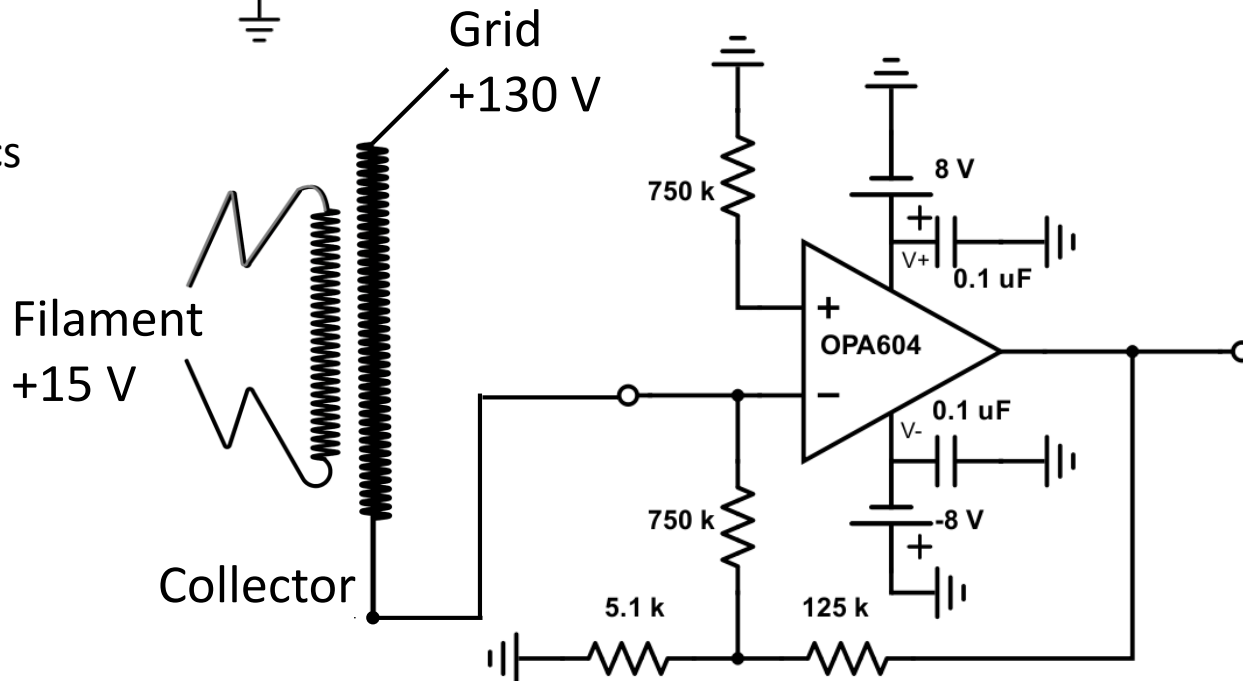

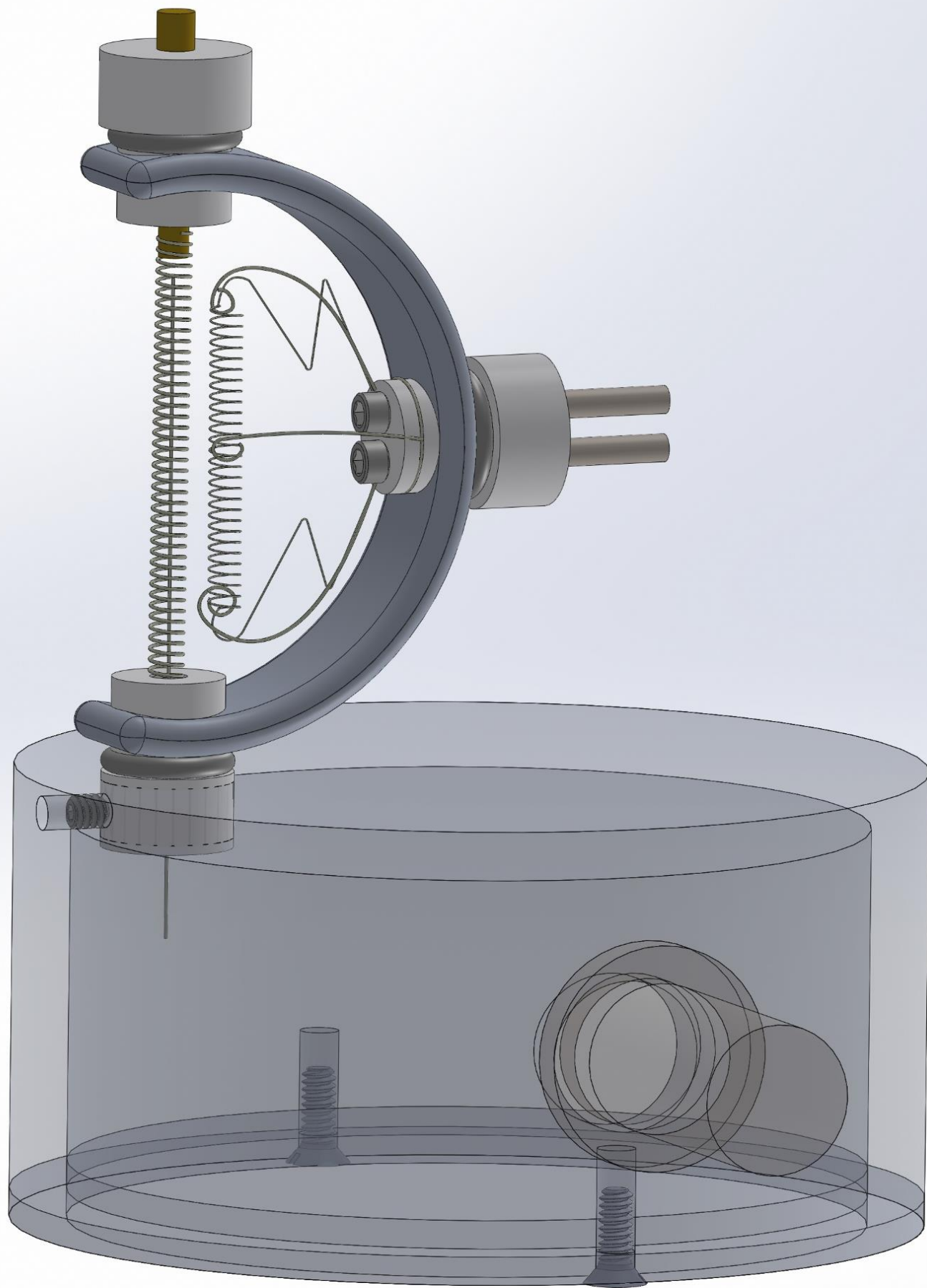

Grid:  
 [0.254] 0.010 Tungsten  
 28 turns/inch  
 [2.54] 0.100 x [40] 1.500

5/16 ID x 1/16 CS o-ring

Filament Supports 3x:  
 [0.254] 0.010 Tungsten

2 x 56 screws secure filament

Epoxy

Filament:  
 [0.127] 0.005 Tungsten  
 28 turns/inch  
 [2.54] 0.100 x [28.58] 1.125

Collector:  
 [0.254] 0.010 x [55.56] 2.1875  
 Tungsten TIG welding  
 electrode

UNLESS OTHERWISE SPECIFIED:  
 DIMENSIONS ARE IN MILLIMETERS  
 SURFACE FINISH:  
 TOLERANCES:  
 LINEAR:  
 ANGULAR:

FINISH:

DEBURR AND  
 BREAK SHARP  
 EDGES

DO NOT SCALE DRAWING

REVISION

	NAME	SIGNATURE	DATE	
DRAWN				
CHK'D				
APPV'D				
MFG				
Q.A				

TITLE:	
DWG NO.	
<b>FIG_head_assembly</b>	
SCALE:1:1	SHEET 1 OF 1

MATERIAL:

WEIGHT:

DWG NO.

SCALE:1:1

SHEET 1 OF 1

A4

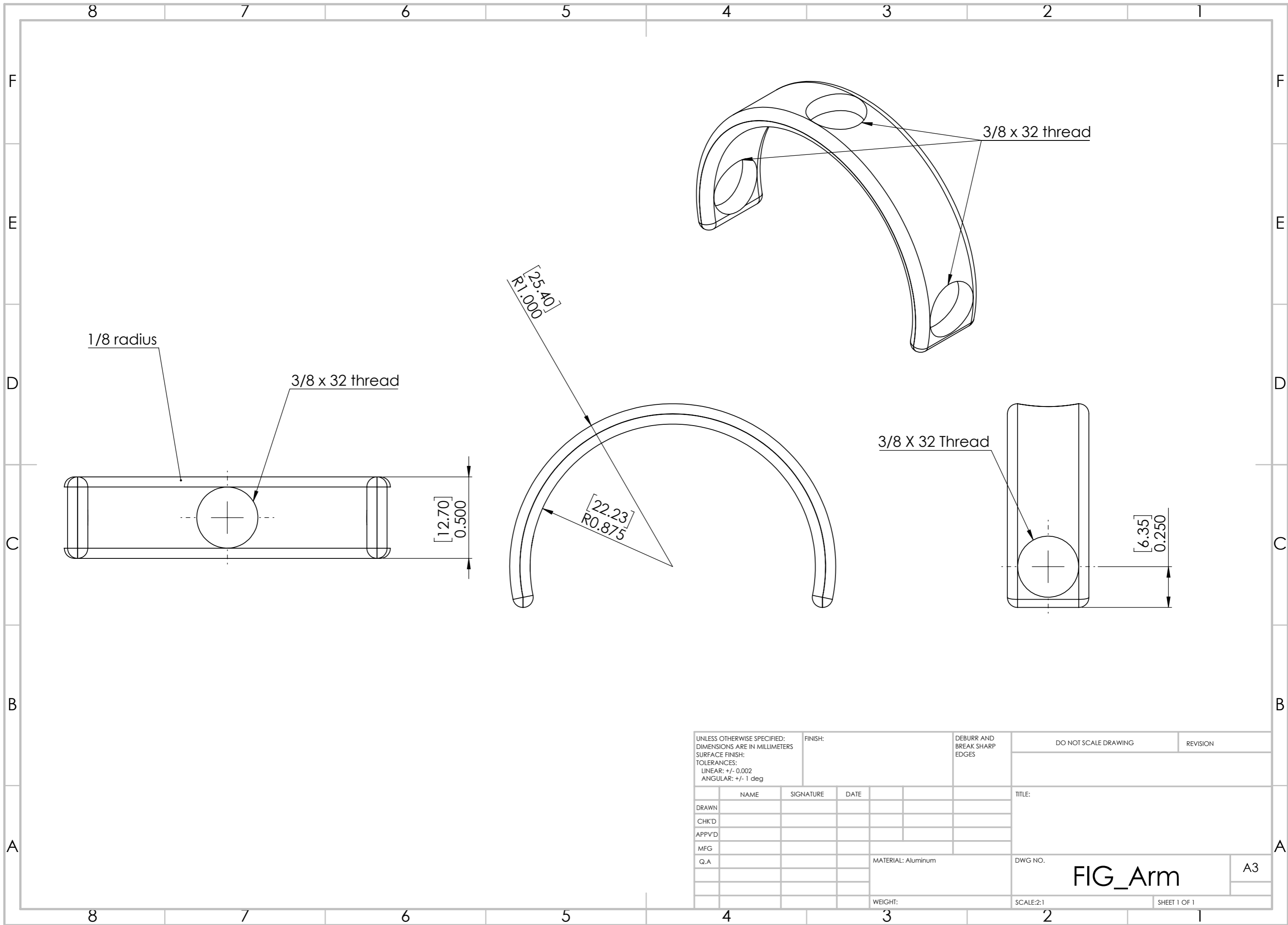

1/8 radius

3/8 x 32 thread

[12.70]  
0.500

[25.40]  
R1.000

[22.23]  
R0.875

3/8 x 32 thread

3/8 X 32 Thread

[6.35]  
0.250

UNLESS OTHERWISE SPECIFIED: DIMENSIONS ARE IN MILLIMETERS SURFACE FINISH: TOLERANCES: LINEAR: +/- 0.002 ANGULAR: +/- 1 deg				FINISH:		DEBURR AND BREAK SHARP EDGES		DO NOT SCALE DRAWING		REVISION	
DRAWN				NAME		SIGNATURE		DATE		TITLE:	
CHK'D											
APPV'D											
MFG											
Q.A								MATERIAL: Aluminum		DWG NO. <b>FIG_Arm</b>	
								WEIGHT:		SCALE:2:1	
										SHEET 1 OF 1	
										A3	

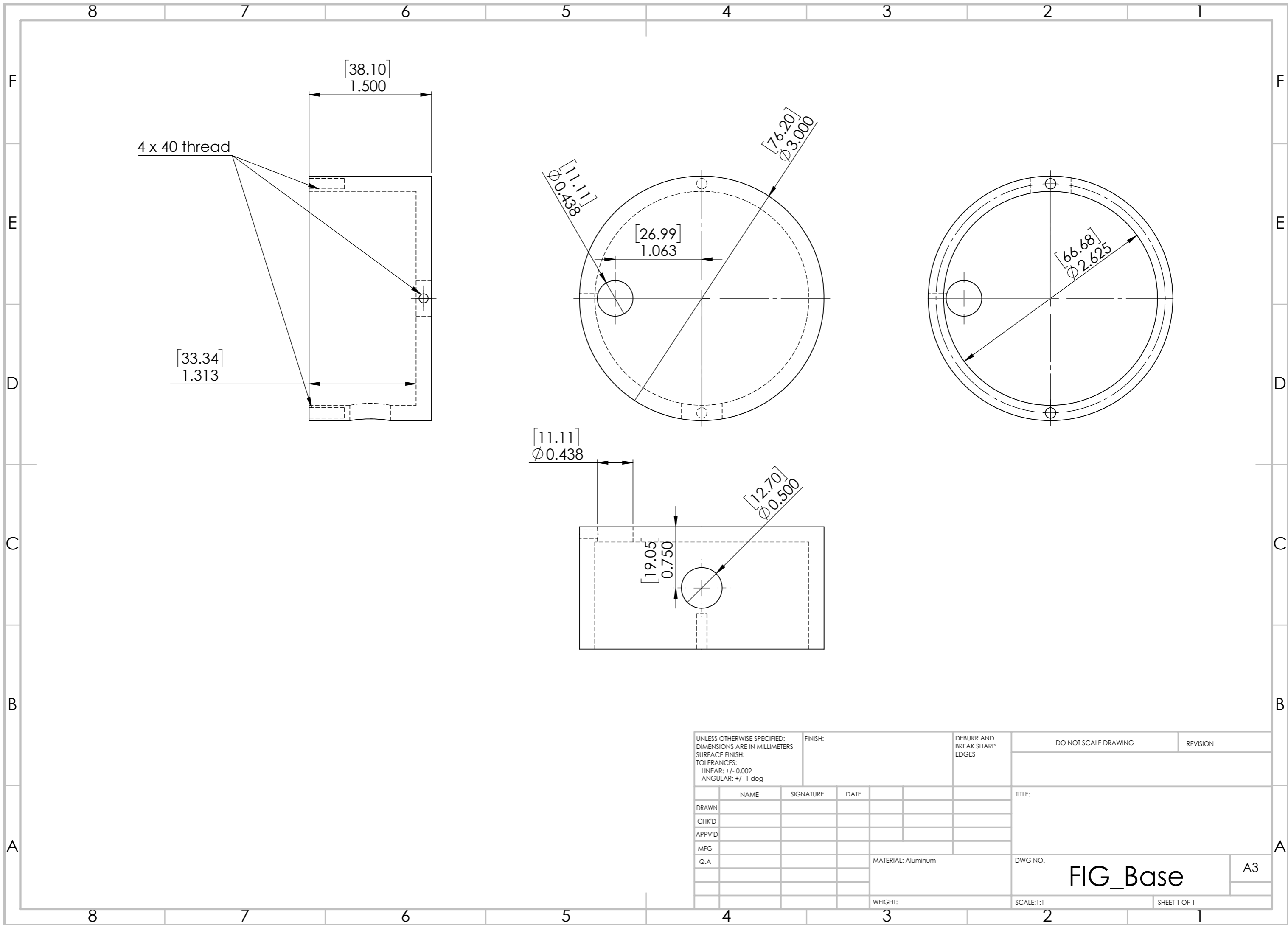

UNLESS OTHERWISE SPECIFIED: DIMENSIONS ARE IN MILLIMETERS SURFACE FINISH: TOLERANCES: LINEAR: +/- 0.002 ANGULAR: +/- 1 deg				FINISH:		DEBURR AND BREAK SHARP EDGES		DO NOT SCALE DRAWING		REVISION	
DRAWN				NAME		SIGNATURE		DATE		TITLE:	
CHK'D											
APPV'D											
MFG											
Q.A								MATERIAL: Aluminum		DWG NO.	
								WEIGHT:		SCALE: 1:1	
										SHEET 1 OF 1	
										FIG_Base	
										A3	



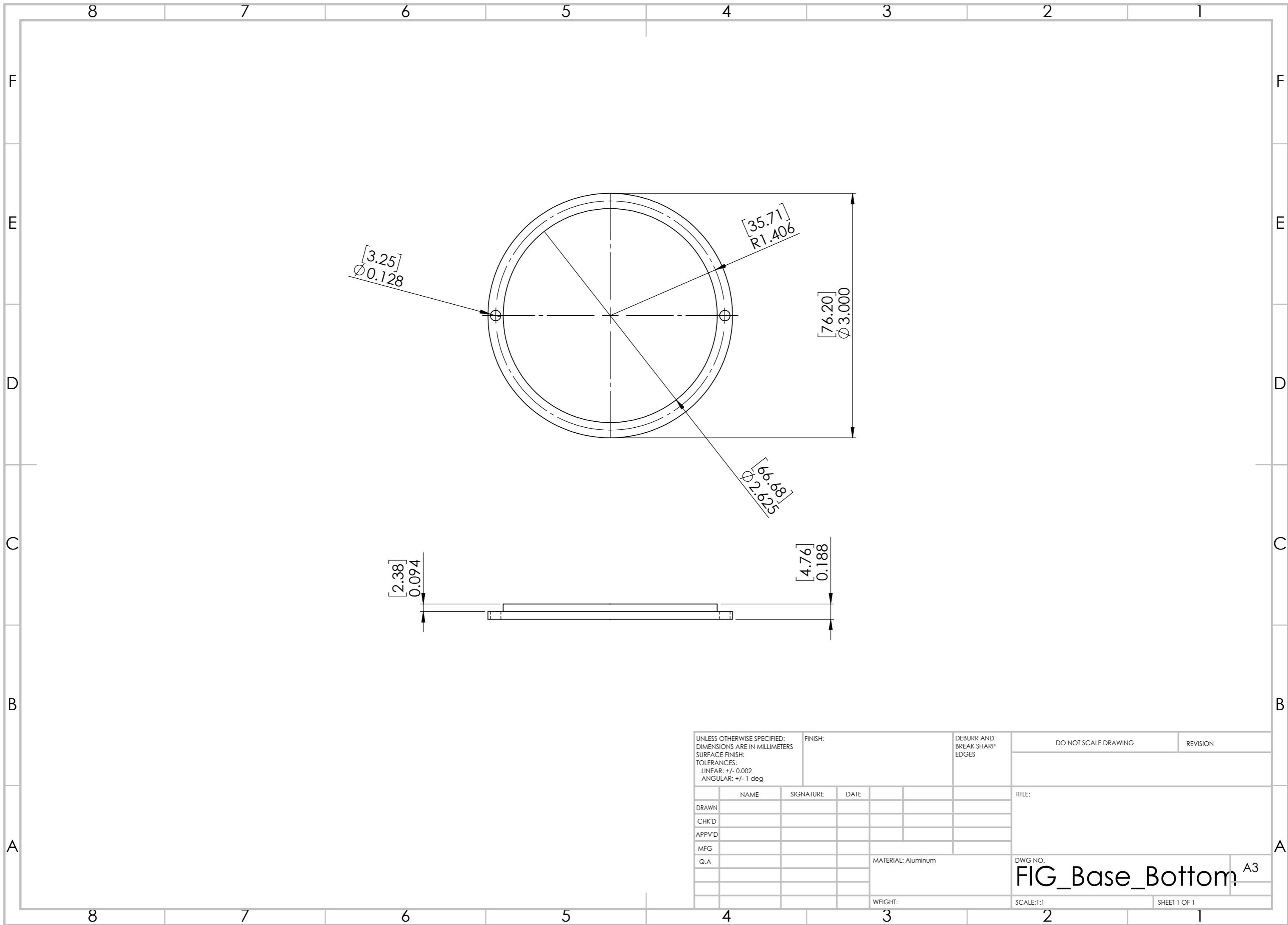

[3.25]  
Ø0.128

[35.71]  
R1.406

[76.20]  
Ø3.000

[66.68]  
Ø2.625

[2.38]  
0.094

[4.76]  
0.188

UNLESS OTHERWISE SPECIFIED: DIMENSIONS ARE IN MILLIMETERS SURFACE FINISH: TOLERANCES: LINEAR: +/- 0.002 ANGULAR: +/- 1 deg				FINISH:		DEBURR AND BREAK SHARP EDGES		DO NOT SCALE DRAWING		REVISION	
								TITLE:			
DRAWN		NAME		SIGNATURE		DATE					
CHK'D											
APPV'D											
MFG											
Q.A								MATERIAL: Aluminum		DWG NO.	
								FIG_Base_Bottom A3			
								WEIGHT:		SCALE:1:1	
										SHEET 1 OF 1	

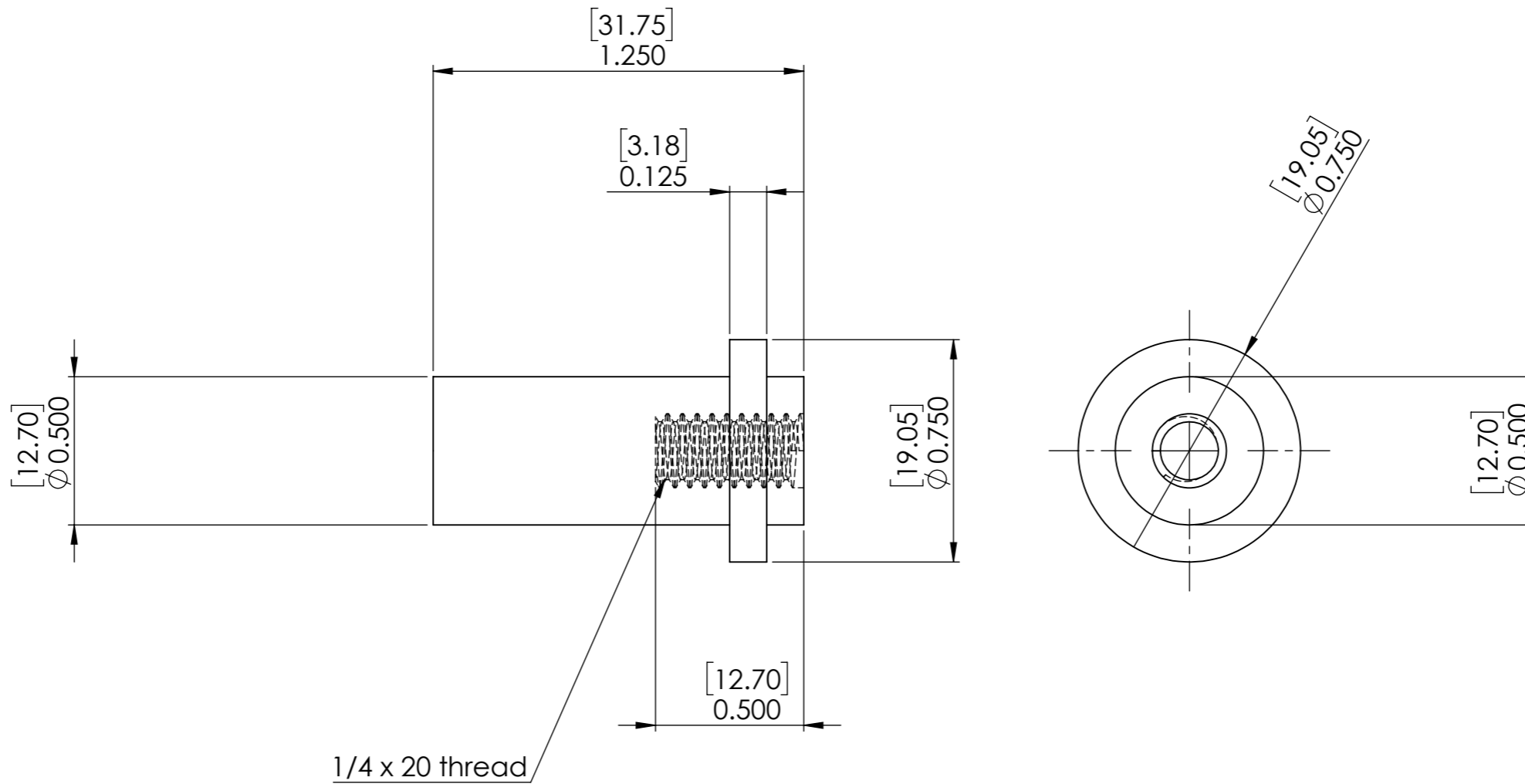

UNLESS OTHERWISE SPECIFIED: DIMENSIONS ARE IN MILLIMETERS SURFACE FINISH: TOLERANCES: LINEAR: +/- 0.002 ANGULAR: +/- 1 deg			FINISH:		DEBURR AND BREAK SHARP EDGES		DO NOT SCALE DRAWING		REVISION		
DRAWN			NAME		SIGNATURE		DATE		TITLE:		
CHK'D											
APPV'D											
MFG											
Q.A							MATERIAL: Stainless Steel		DWG NO.		
									FIG_Base_Pin		
							WEIGHT:		SCALE:2:1		
									SHEET 1 OF 1		
									A3		

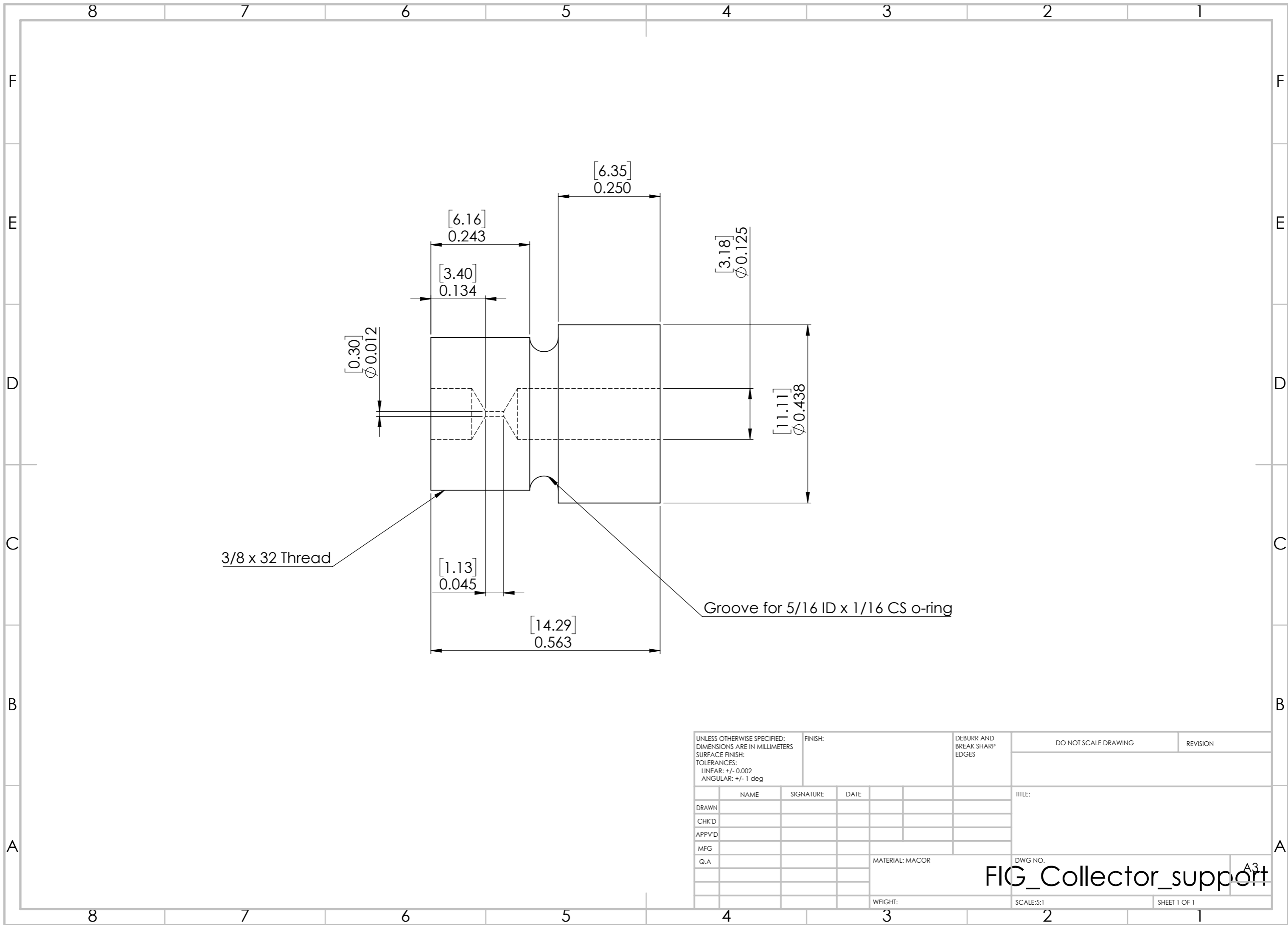

3/8 x 32 Thread

Groove for 5/16 ID x 1/16 CS o-ring

UNLESS OTHERWISE SPECIFIED: DIMENSIONS ARE IN MILLIMETERS SURFACE FINISH: TOLERANCES: LINEAR: +/- 0.002 ANGULAR: +/- 1 deg				FINISH:		DEBURR AND BREAK SHARP EDGES		DO NOT SCALE DRAWING		REVISION	
DRAWN				NAME		SIGNATURE		DATE		TITLE:	
CHK'D											
APPV'D											
MFG											
Q.A								MATERIAL: MACOR		DWG NO.	
								WEIGHT:		SCALE: 5:1	
										SHEET 1 OF 1	

FIG\_Collector\_support

A3

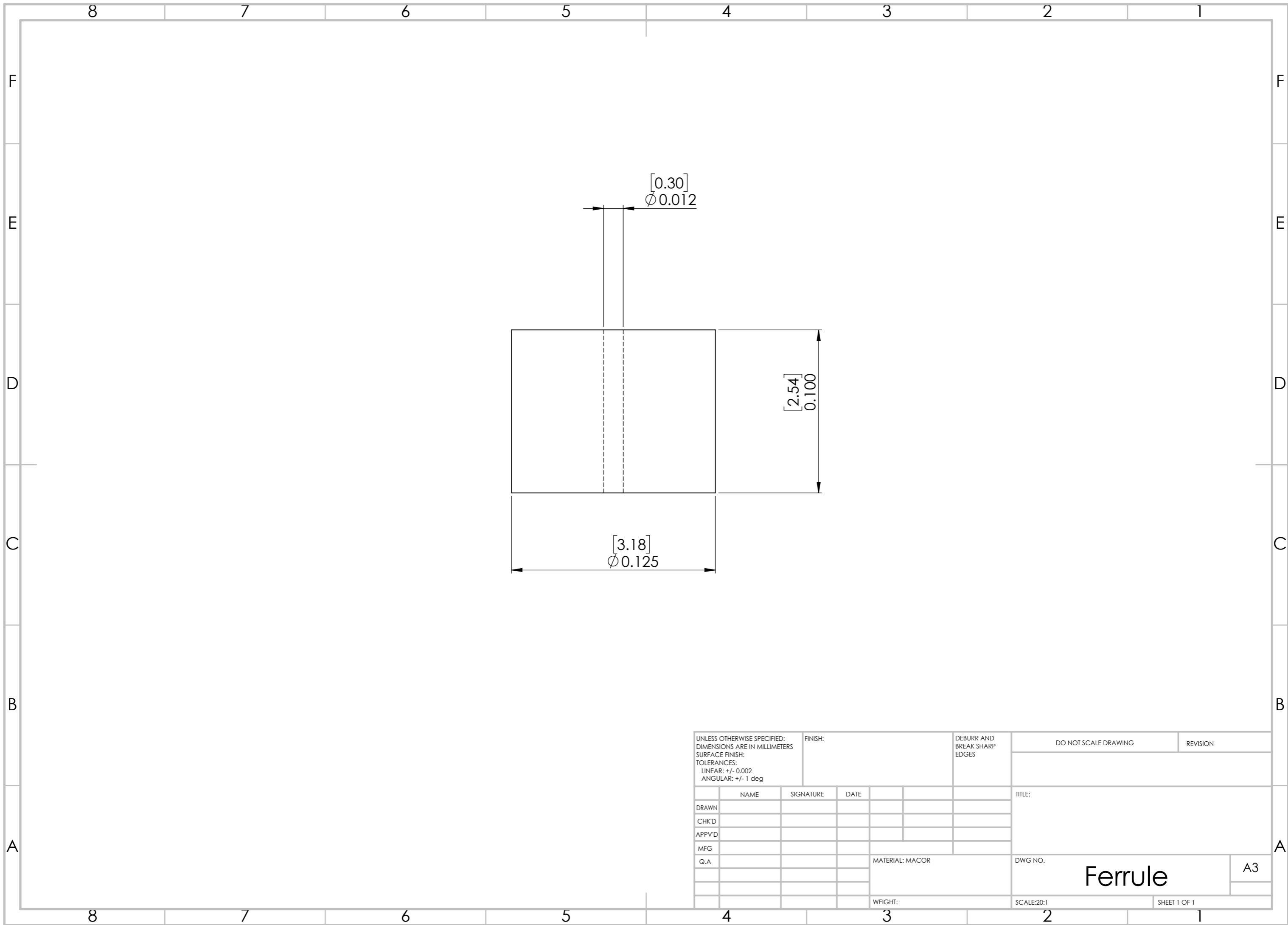

UNLESS OTHERWISE SPECIFIED: DIMENSIONS ARE IN MILLIMETERS SURFACE FINISH: TOLERANCES: LINEAR: +/- 0.002 ANGULAR: +/- 1 deg				FINISH:		DEBURR AND BREAK SHARP EDGES		DO NOT SCALE DRAWING		REVISION	
						TITLE:					
DRAWN	NAME	SIGNATURE	DATE								
CHK'D											
APPV'D											
MFG											
Q.A						MATERIAL: MACOR		DWG NO.		A3	
				WEIGHT:		SCALE:20:1		SHEET 1 OF 1			

Ferrule

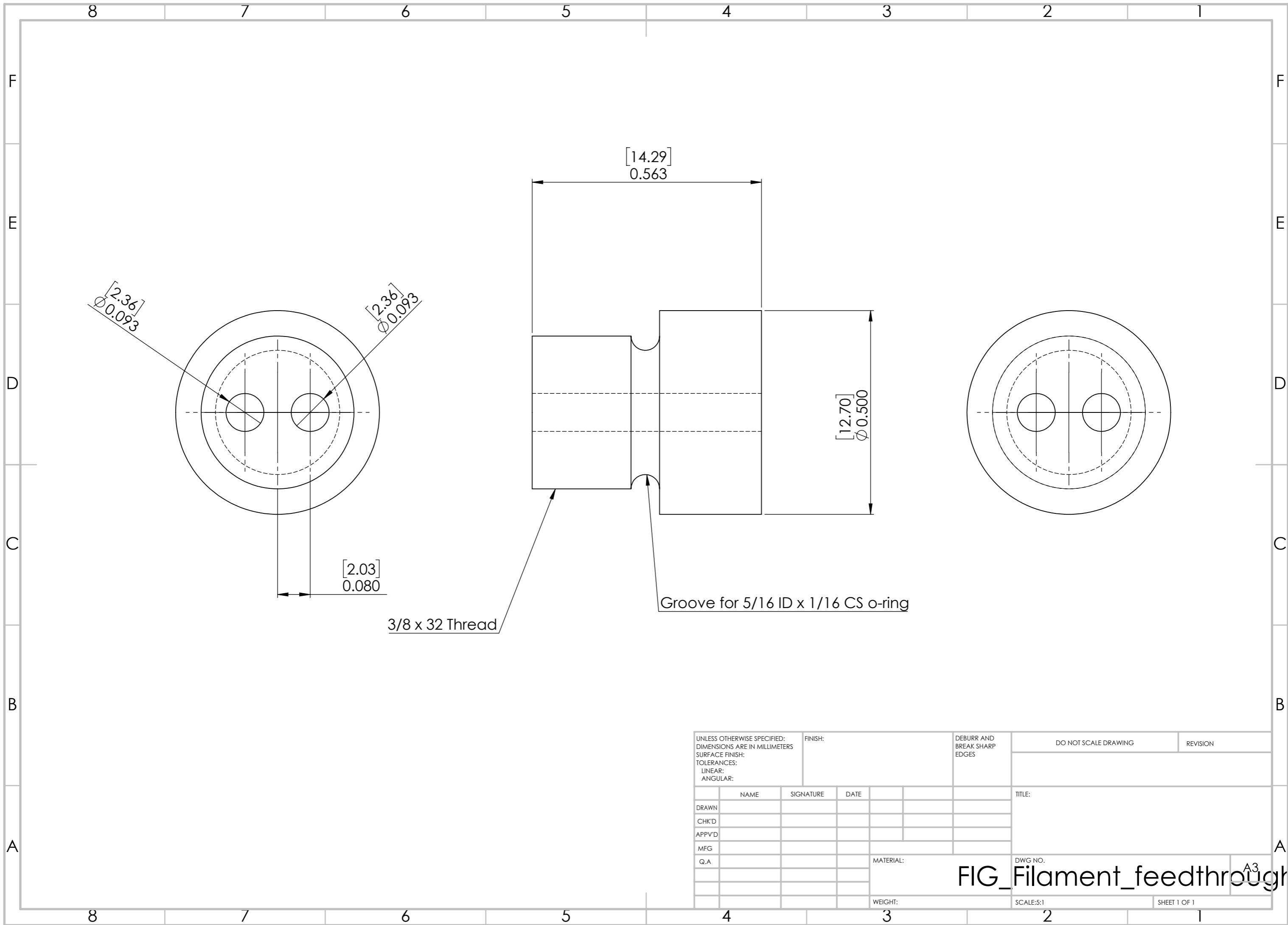

UNLESS OTHERWISE SPECIFIED: DIMENSIONS ARE IN MILLIMETERS SURFACE FINISH: TOLERANCES: LINEAR: ANGULAR:			FINISH:		DEBURR AND BREAK SHARP EDGES		DO NOT SCALE DRAWING		REVISION		
DRAWN			NAME		SIGNATURE		DATE		TITLE:		
CHK'D											
APPV'D											
MFG											
Q.A							MATERIAL:		DWG NO.		
							WEIGHT:		SCALE:5:1		
									SHEET 1 OF 1		

FIG\_Filament\_feedthrough

A3

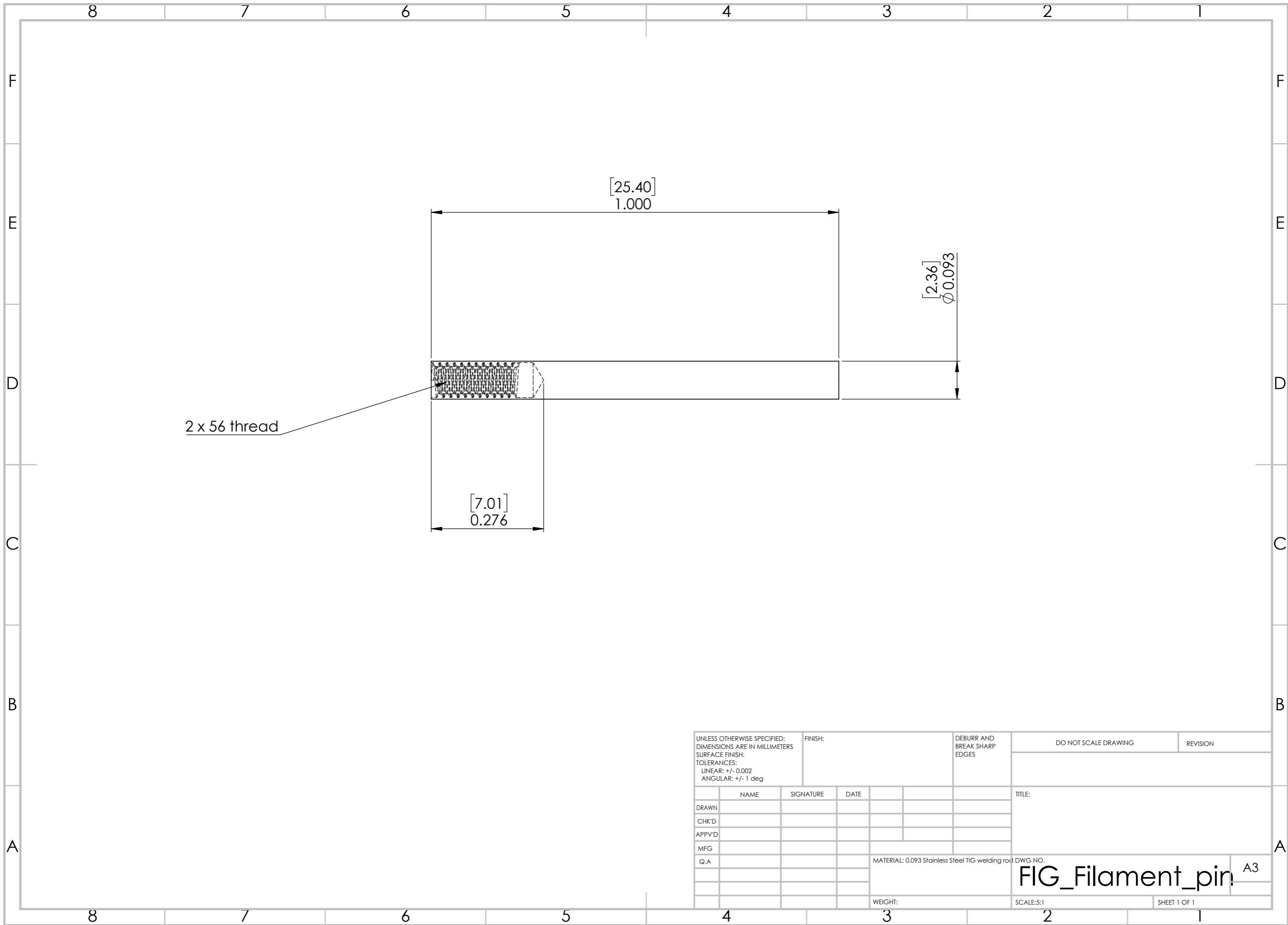

2 x 56 thread

[25.40]  
1.000

[2.36]  
Ø 0.093

[7.01]  
0.276

UNLESS OTHERWISE SPECIFIED: DIMENSIONS ARE IN MILLIMETERS SURFACE FINISH: TOLERANCES: LINEAR: +/- 0.002 ANGULAR: +/- 1 deg				FINISH:		DEBURR AND BREAK SHARP EDGES		DO NOT SCALE DRAWING		REVISION	
								TITLE:			
DRAWN		NAME		SIGNATURE		DATE					
CHK'D											
APPV'D											
MFG											
Q.A											
MATERIAL: 0.093 Stainless Steel TIG welding rod DWG NO.								A3			
WEIGHT:								SCALE:5:1		SHEET 1 OF 1	

FIG\_Filament\_pin

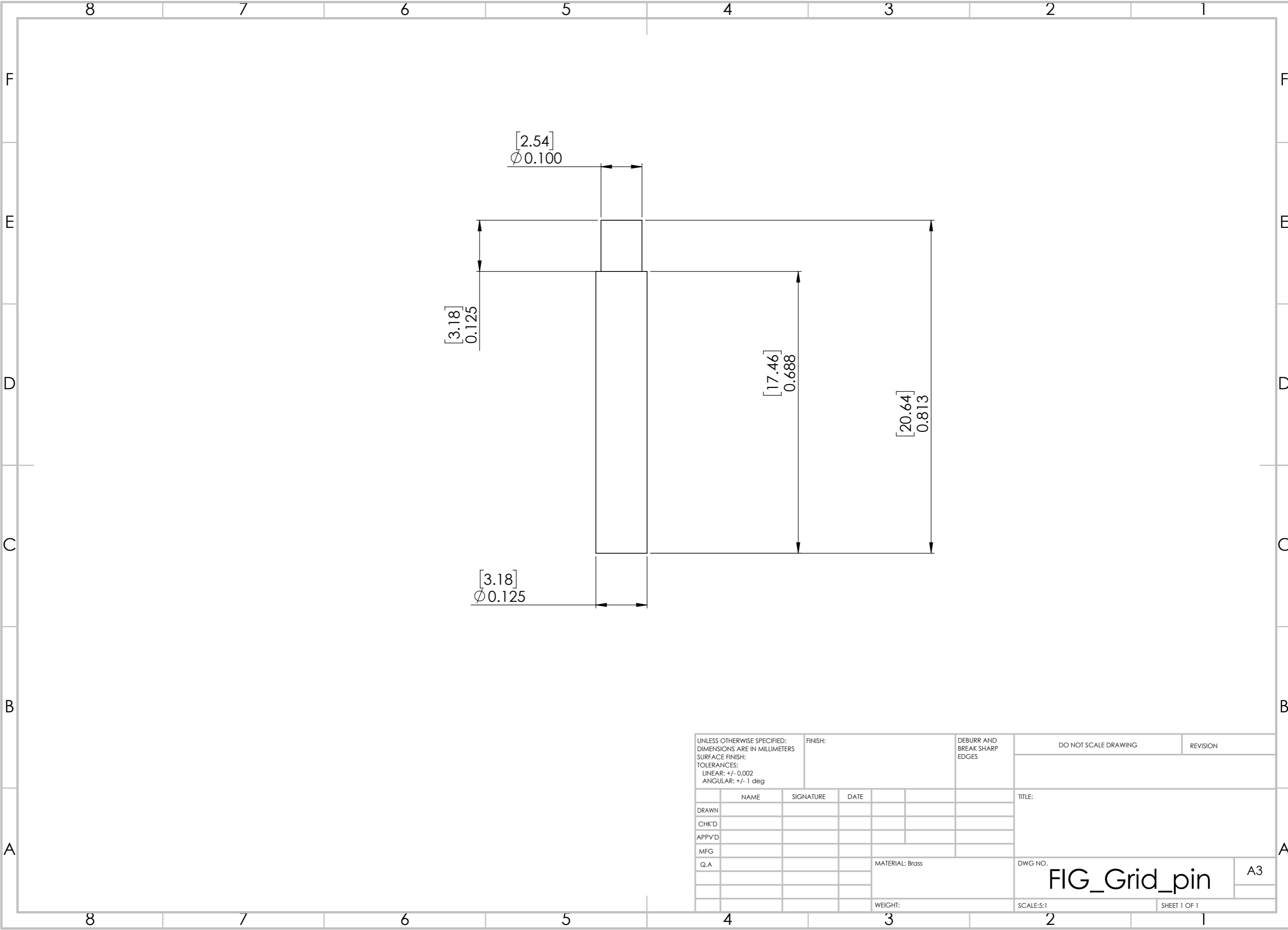

UNLESS OTHERWISE SPECIFIED: DIMENSIONS ARE IN MILLIMETERS SURFACE FINISH: TOLERANCES: LINEAR: +/- 0.002 ANGULAR: +/- 1 deg				FINISH:		DEBURR AND BREAK SHARP EDGES		DO NOT SCALE DRAWING		REVISION	
DRAWN				NAME		SIGNATURE		DATE		TITLE:	
CHK'D											
APPV'D											
MFG											
Q.A								MATERIAL: Brass		DWG NO. <b>FIG_Grid_pin</b>	
								WEIGHT:		SCALE: 5:1	
										SHEET 1 OF 1	
										A3	

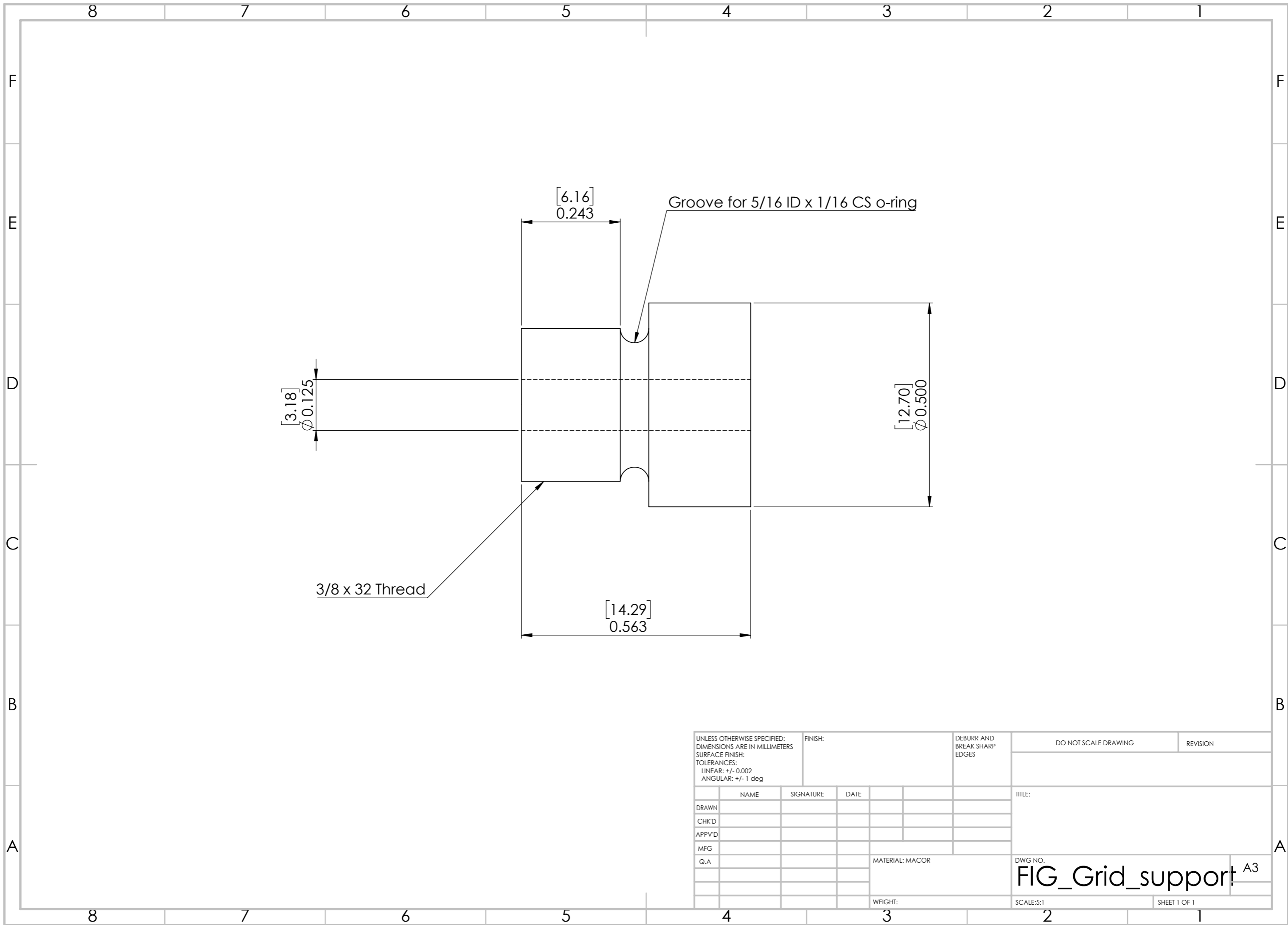

UNLESS OTHERWISE SPECIFIED: DIMENSIONS ARE IN MILLIMETERS SURFACE FINISH: TOLERANCES: LINEAR: +/- 0.002 ANGULAR: +/- 1 deg				FINISH:		DEBURR AND BREAK SHARP EDGES		DO NOT SCALE DRAWING		REVISION	
DRAWN				NAME		SIGNATURE		DATE		TITLE:	
CHK'D											
APPV'D											
MFG											
Q.A								MATERIAL: MACOR		DWG NO.	
										FIG_Grid_support A3	
								WEIGHT:		SCALE:5:1	
										SHEET 1 OF 1	